



KATOOL

www.katoolautoequip.com

Auto Body Collision Repair System

Car Bench KT-299U

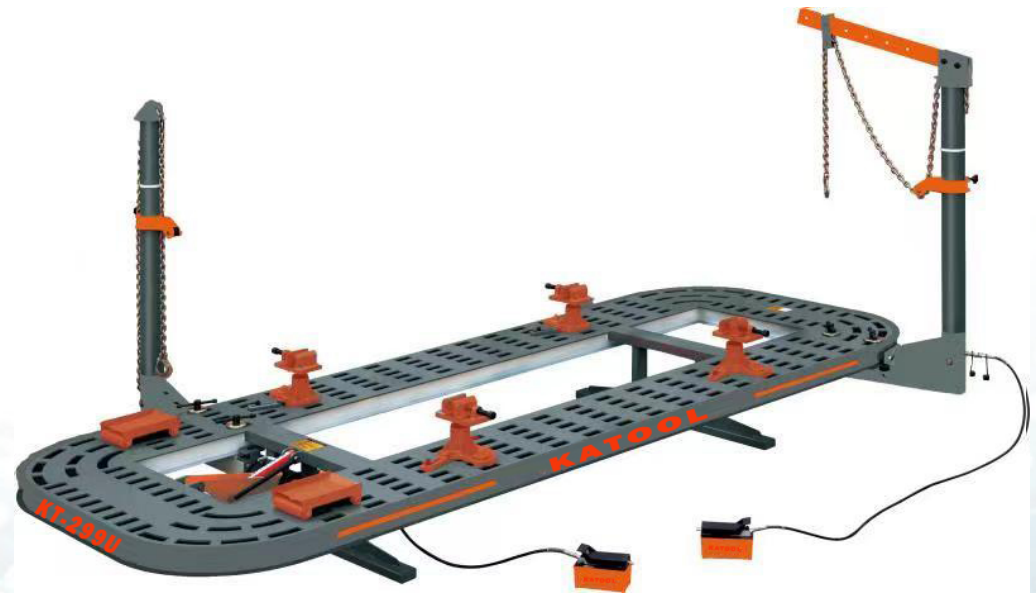

KATOOOL KT-299U

KT-299U, working platform made of fate plate and square holes steels is designed professionally for body collision repair by choosing better material, improving welding technique and enhancing stress intensity to make the repairing work more precise and faster. One of important features is no-blind working range, which is in accord with the technician's habit to make more convenient operation. It can be widely used for nearly all kinds of small cars, MPV,SUVs ,Pickup trucks and business vehicles.

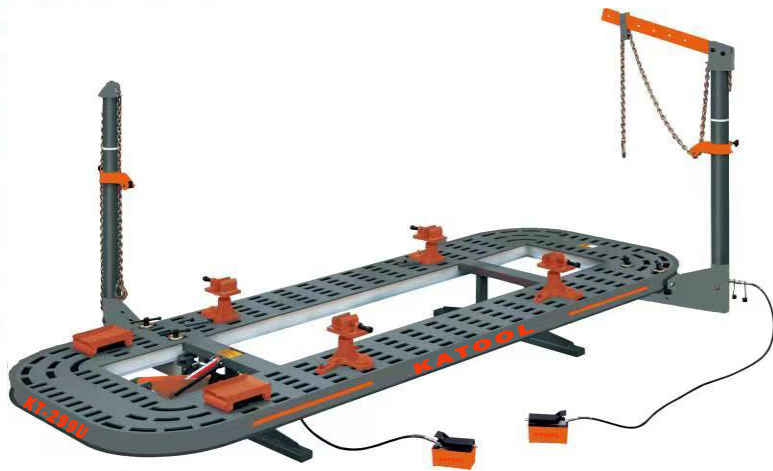

Specifications:

Main technical parameter	
Frame Length	5600MM/6000MM/6500mm
Width	2200MM
Height	520MM
Pulling capacity	95KN
Radius of pulling	360°
Max. loading Capacity	3500KG
Air supply required	0.8MPA

Drawing

Single platform width is 600mm ,middle distance is 1000mm, this structure makes the platform stronger and safer when driving vehicles on the machine.

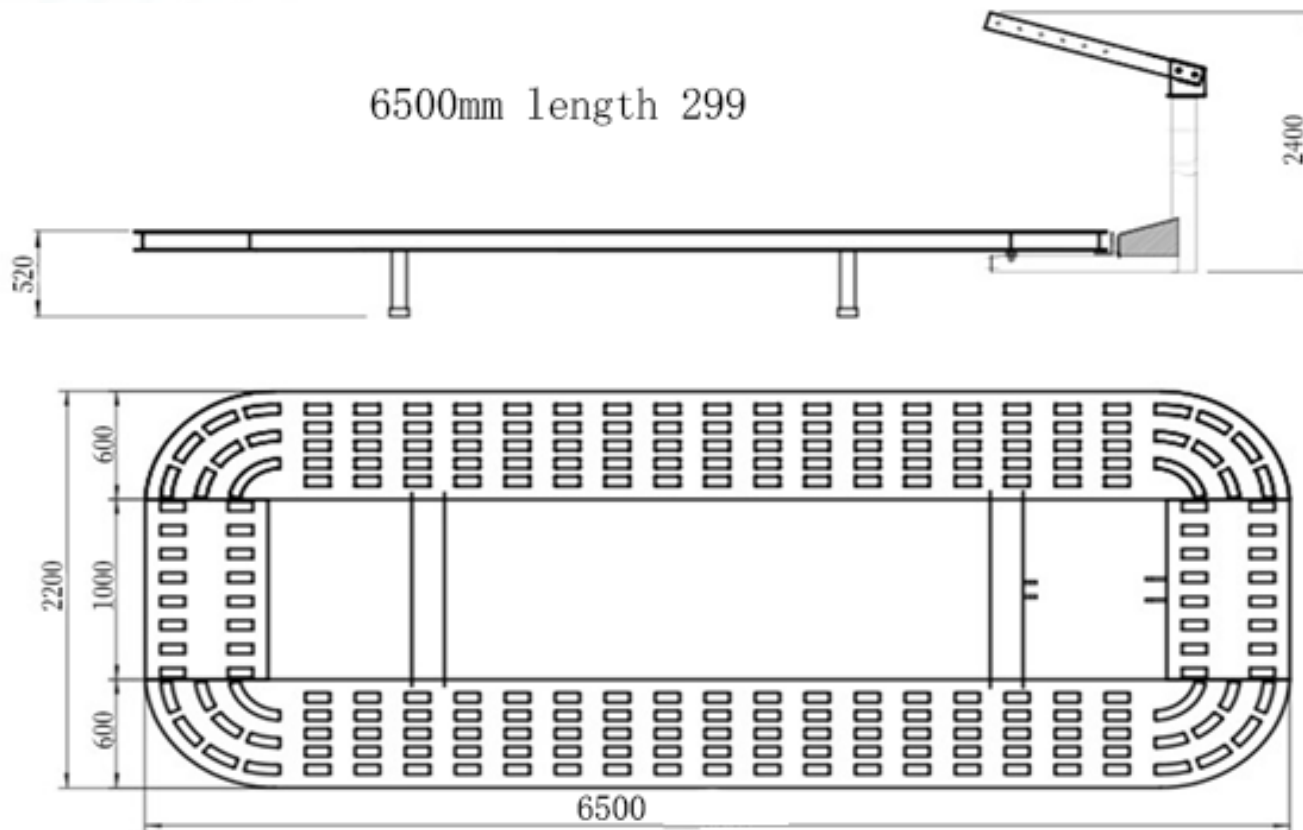

Features:

- ● Platform is made of high-quality manganese steel, procedures including CNC plasma cutting, CO2 welding (Panasonic), polishing (shot blasting cleaning machine) and power coating ensure the platform with high flatness, strong anti-torsion strength, no-blind fixing ways and efficient straightening.
- ● Tilt hydraulic lifting platform makes the accidental vehicle loaded and unloaded more conveniently (even drive the car onto the platform directly).
- ± ● The strength of platform is decided by the connected steel beams on the top and bottom. Thickness of platform steel is 10mm, width of each half platform is 600mm assembled by 5 rows of square holes, each hole has a crossed-shape beam with external side thickness 8mm and internal side thickness 6mm, which assure the whole platform is flat and strong enough.

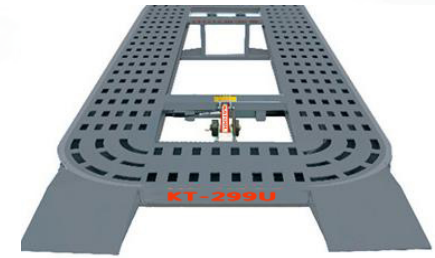

Features:

- ● Towers can be rotated 360 degrees along the platform and be made of 10mm seamless steel pipe, which means more convenient moving and high intensity if both towers straighten in diagonal line.
- ● Unique design of spiral movements for main clamps is easier to make jaws upper and lower on precondition of maintaining the flat level by adjusting the pole vertically to clamp different height chassis of all kinds of vehicles. Quick fixed clamp jaws by screwing the shaft clockwise, making chassis clamping more efficient.
- ± ● All accessories and tools are mechanical streamline design and have durable life by multi-heating and forging processes.
- ± Three important points for heat treatment process to make sure the accessories quality:
 - ± Overall forging (mould owned by UNLINER)
 - ± Overall conditioning (hardness HRC28 degrees);
 - ± High frequency quenching of tooth profile (hardness HRC40 degrees).

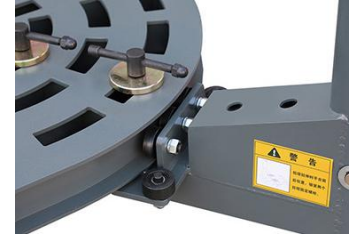

Features:



- ● The leading arm can supply multi-direction tensile during the collision repair.
- ● Durable American Eagle Pro Hydraulic foot pumps.
- ± ● High-precision and retractable alloy two dimension measurement has no breaking point, can be realized three-dimensional measurement.
- ± Car data with global synchronization offered by Mitchell and major auto manufactures to make sure the latest update.(optional)



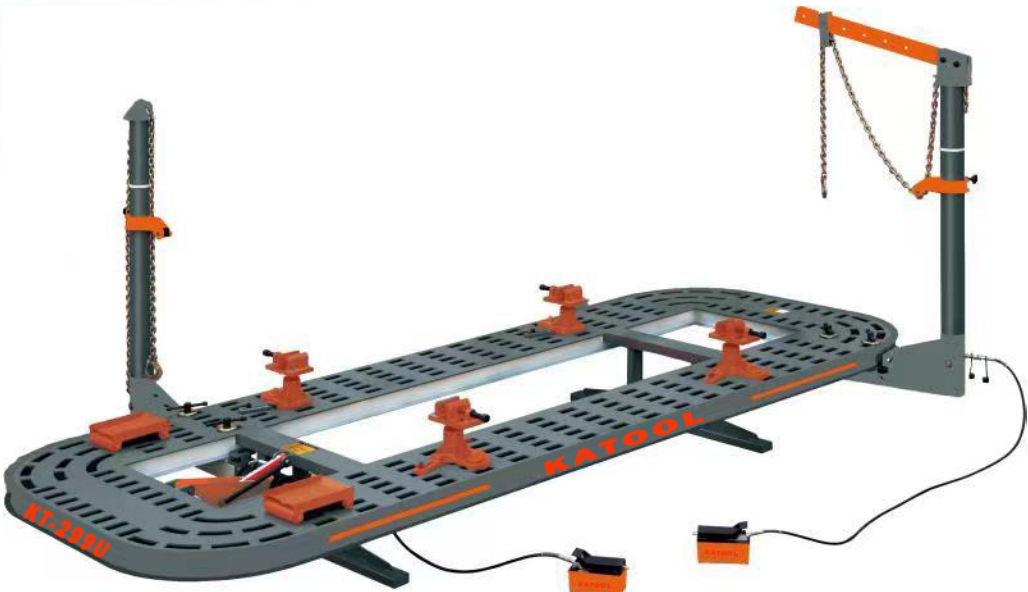

(Optional)

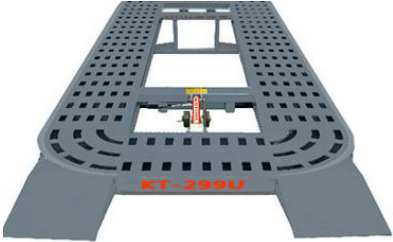
KT-299U Configuration List









No.	Parts included	Quantity (set)	Remark
1	KT-299U	1	
			
1)	Fixed support leg	1	
2)	Movable support leg	1	

3)	Tilt- lift of platform (include oil cylinder)	1	
4)	Ramps	2	
3	Tiger main clamp	4	
1)	Foot for fixing jaws clamp (M12 bolts)	4	
2)	Screw clamp of tiger main clamp	4	
3)	Bolts, pressure plate, nut for fixing jaws main clamp	4	

3	360° rotation Pulling towers	2	
1)	Push rod of cylinder	2	
2)	Bolts for fixing towers	4	
3)	Bolt plates for fixing towers	4	
4)	Nut for fixing towers	4	
5)	in-built adjustable collars	2	
6)	Main chain(with chain hook)	2	
7)	Protective wire	2	
8)	10T high pressure cylinder	2	
9)	Leading arm 、 U-shape shelf 、 chain wheel	1	
4	Two-dimensional measurement system(optional)	1	
5	Pneumatic pump (including oil pump、 the quick couplers)	2	

6	Tools board & accessories	1	
2)	Chains with rake body	1	
3)	Small clamp	1	
4)	Mini clamp	1	
5)	Width clamp	1	
6)	Crescent spanner	1	

7)	Right angle clamp	1	
8)	Scissor clamp	1	
10)	Big bending hook (1-3)	1	
11)	Deep hook	1	
12)	Strut puller kit	1	
13)	Slotted Chain Anchor	2	
14)	C-clamp	1	
15)	Big and small steel hocks	1set	

15)	Multi hole pull plates	1	
16)	nylon sling	1	
18)	Steel wire	1	
19)	Handy link	1	
20)	Double Chain Hook	1	
21)	Down-pulling Device	1	
22)	Wheel dolly	2	
7	Data base	1	



KATOOOL

www.katoolautoequip.com

Contact Us

Sales: 447-902-3857

Technical: 716-299-8852

Email:

info@autokato.com

City of Industry, CA

Brookshire, TX

Pooler, GA

Bolingbrook, IL

Jersey City, NJ