

Daytona

Tilt Tire Changer

TC-890T



User Manual



Model: TC-890T Serial No. _____

Symbol and code printed

In the manual, the following symbols and codes is for the convenience of reading.

	need careful operation
	prohibited
	may cause dangerous to the operator
Bold	Important info

	Warning: Before lifting and any adjustment, carefully read the Chapter 7 "Installation" among which it is the operation suitable for the best lift.
---	--

CONTENT

Chapter1 Introduction-----	1
Chapter 2 General information-----	1
Chapter 3 Transportation, Unpackage and Storage-----	4
Chapter 4 Installation-----	5
Chapter 5 Operation-----	11
Chapter 6 Inflation-----	15
Chapter 7 Operation and Installation of the helper-----	16
Chapter 8 Maintenance-----	24
Chapter 9 Troubleshooting-----	26
Chapter 10 Electrical and Pneumatic scheme-----	27

Chapter 1 Introduction

1.1 Introduction

This product is based on the best quality principal. Following the simple instruction in this manual can ensure the correct operation and prolong the life of the machine. Read the manual thoroughly and ensure that you have understood it.

1.2 Tire changer identification data

The complete description of the model and series number can make our technical department provide the service more easily. And it is also convenient for the shipment of the spare parts. We add the data of the tire changer in the following column. If there is any difference between the data in the manual and the data on the nameplate, we should consider the nameplate attached on the machine to be correct.

voltage: ampere: kilowatt:
phase: hertz:
air supply: 8-10bar (115-145PSI)

1.3 Keep of the manual

To correctly use this manual, we suggest as follows:
Keep the manual easy to pick up
Keep the manual in the condition moisture-resistant
Properly use this manual and do not damage it
The operator of the machine must familiar with the instruction and program in the manual

This manual is the integrated part of the product. It should be provided to the new owner when the machine is resold.

 The components and parts on the picture may be different from the actual ones .

1.4 General safety precaution

 The tire changer should be operated by the professional personnel specially authorized.

Chapter 2 General information

2.1 Purpose

This automatic tire changer is designed and manufactured to mount/demount the rim.

We hereby state that the manufacturer will not bear the responsibility to the damage arising from the use not stated in the manual or improper, incorrect and unreasonable.

2.2 Instruction to the part of the machine

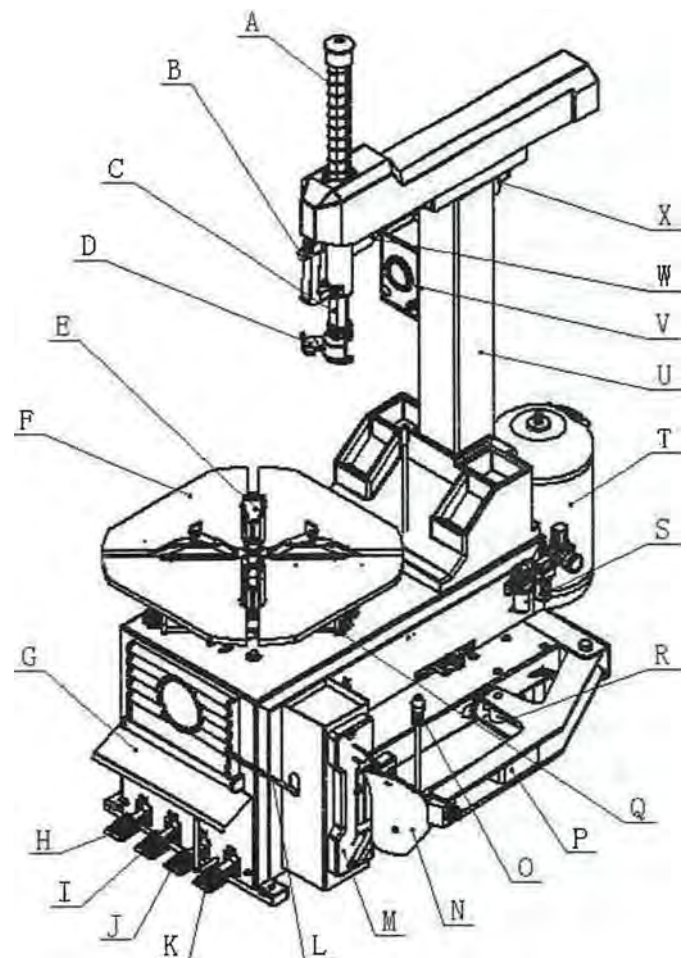

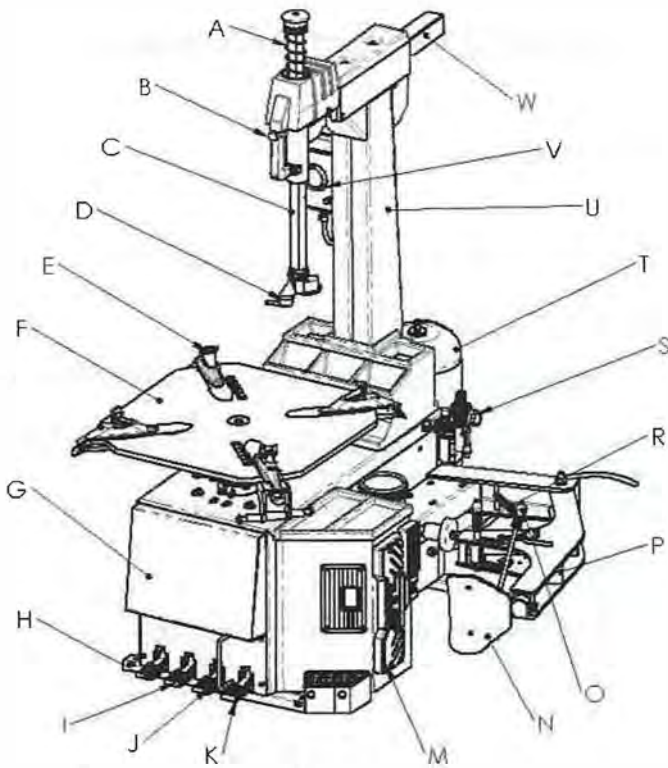

Fig 2-1

- A vertical shaft spring
- B. manual valve lock button
- C. hex shaft
- D. tool head
- E. clamping jaw
- F. turntable
- G. front panel
- H. column tilt back pedal
- I. clamping pedal
- J. bead breaker pedal
- K. turntable rotation pedal
- L. crowbar
- M. tire support
- N. blade
- O. blade handle
- P. bead breaker arm
- Q. clamping cylinder
- R. bead breaker cylinder
- S. air regulator
- T. air tank
- U. column

- V. inflation gauge box
- W. horizontal arm
- X. lock cylinder

2.3 Dangerous warning stick



Keep the hands away carefully read the Wear the protection

from tire when operating manual before using device when operating



Electrical shock !



Do not position any part of your body under the tool head.



When bead breaking, the blade will move leftwards very fast and the operator should not stand between the blade and tire.



When blast inflation, you must secure the wheel is firmly fixed

When operating, you should not wear long hair, loose suit and jewelry

When operating, do not reach your hand under the fallen parts.



Note: When press the tire, if the clamping cylinder is open, it will scratch the hand of the operator. Keep in mind that the hand should not contact the side wall of the tire.



When clamping the rim, do not place the hand and the other part of the body in between the clamping jaw and rim.



Do not stand behind the column avoiding injure the personnel when the column swing.

SAFETY LABEL POSITION DIAGRAM

Pay attention to keep the safety labels complete. When it is not clear of missing, you should change the new label.

You should let the operators see the safety labels clearly and understand the meaning of the label.

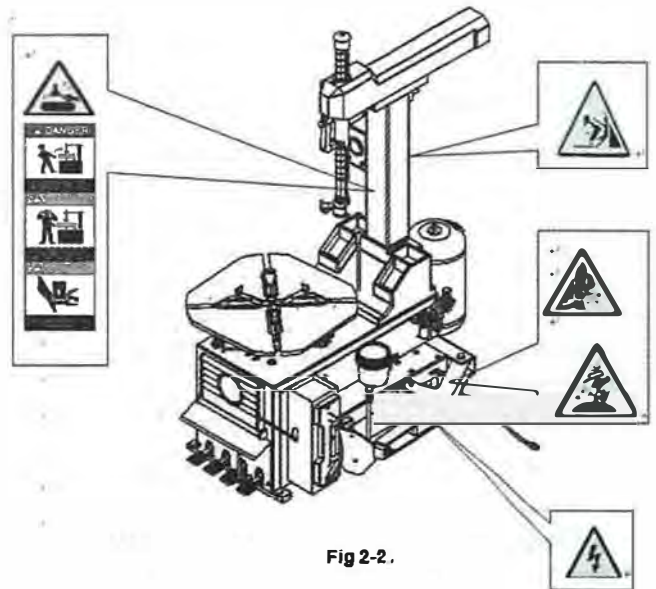

Fig 2-2.

Fig 2-2

2.4 Technical specification (standard configuration): 885IT

Inward clamping size (inch)	10-20
Outward clamping size (inch)	12-24
Max. tire size (inch)	24 (610mm)
Max. tire breadth (inch)	12 (305mm)
Bead breaking force (10bar)	2500kg
Work pressure	10bar (145PSI)
Max. inflation	3.5bar (50PSI)

pressure	
Power supply	220V/380V230V/400V 3PH
	110V 220V 230V 1PH
Motor power	0.75 (3phase, single speed)
	0.85/1.1kw (3phase, dual speed)
	1.1kw (single phase)
Rotation speed	7-14rpm
Max. spindle torque	1200NM
Packing size	1400×880×980
N.T	243kg STND 310kg GT
Work noise	< 70dB (A)
Ambient temperature	-5℃~45℃
R.H	30%~95%
Sea level	Max. 1000M

pressure	
Power supply	220V/380V230V/400V 3PH
	110V 220V 230V 1PH
Motor power	0.75 (3phase, single speed)
	0.85/1.1kw (3phase, dual speed)
	1.1kw (single phase)
Rotation speed	7-14rpm
Max. spindle torque	1200NM
Packing size	1480×1050×1050
N.T	387kg STND 430kg GT
Work noise	< 70dB (A)
Ambient temperature	-5℃~45℃
R.H	30%~95%
Sea level	M1000M

Technical specification (standard configuration): :

895IT

Inward clamping size (inch)	13-24
Outward clamping size (inch)	15-26
Max. tire size (inch)	26 (610mm)
Max. tire breadth (inch)	15 (305mm)
Bead breaking force (10bar)	2500kg
Work pressure	10bar (145PSI)
Max. inflation	3.5bar (50PSI)

Chapter 3 Transportation

Unpacking and Storage

3.1 Transportation

The transportation of the tire changer needs the original package.

The tire changer packed needs to be transported by the forklift with the proper load. Insert the fork into the position indicated in Fig 3.1.

Chapter 4 Installation

4.1 Choice of the space



When you choose the installation site, you should make sure it is corresponding to the current safety regulation.

The tire changer must be connected with the power supply and pneumatic source, therefore, we suggest to choose the installation site of the tire changer to the location near the power supply and pneumatic source to guarantee the correct operation of all the parts of the machine. If the machine is installed outdoors, the machine should be equipped with the shed.



The tire changer with the motor should not be used in the environment with the potential of exploded.

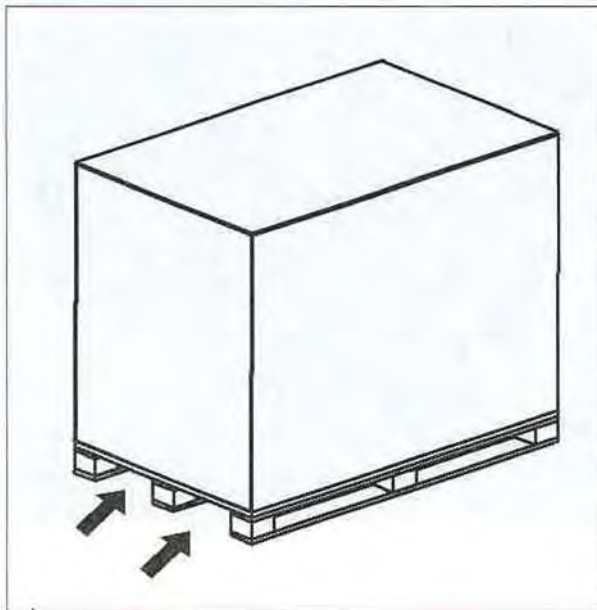

885IT
Standard: 243Kg.
GT:310Kg
895IT
Standard: 387Kg.
GT:430Kg

Fig3.1

3.2 Unpacking

Remove the cardboard and nylon bag for protection
Check if the equipment is intact and make sure there is not any part lost or damaged.



If question, do not use the machine and contact the retailer.

3.3 Storage

If you need long time of storage of the equipment, you should secure the electrical supply is switched off and lubricate the clamping jaw guide rail on the turntable to avoid the oxidization.

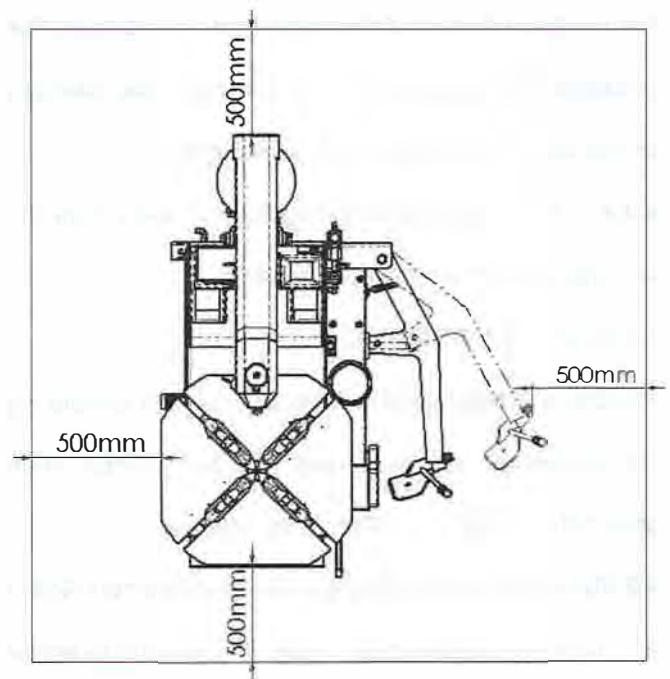

4.2 Parts assembly

4.2.1 Column assembly

Carefully read the manual before installation, any modification to the parts without the permission of the manufacturer may cause the damage to the machine.

The personnel to execute commission must have some knowledge of electricity.

The operator must under the special trained and be authorized.

Carefully check the equipment list, if any question, contact the dealer or the manufacturer immediately. To secure the success of the installation and commission, you should prepare the following common tools:

Two wrenches (10") , one socket wrenches, one hexangular wrench, one tung and one screw driver, one hammer and one multi-purpose meter

4.2.2 DEPACKAGE

4.2.3 According to the de-package instruction on the package box, to detach the box and remove the package material to check if the machine damage or not and if the spare parts completed.

4.2.4 Keep the package material far away from the working site and deal with it properly.

4.2.5 COLUMN INSTALLATION

Position the body base on the ground and unpacking the accessory box and take out the rotation shaft assembly. (Fig4-2 B) Clean and lubricate.

4.2.6 Unscrew the fix screw on the side panel (Fig4-2 A) . Take out the side panel (Fig4-2 B) and the fix screw Fig4-2 C) on the tool box. Take out the tool box.

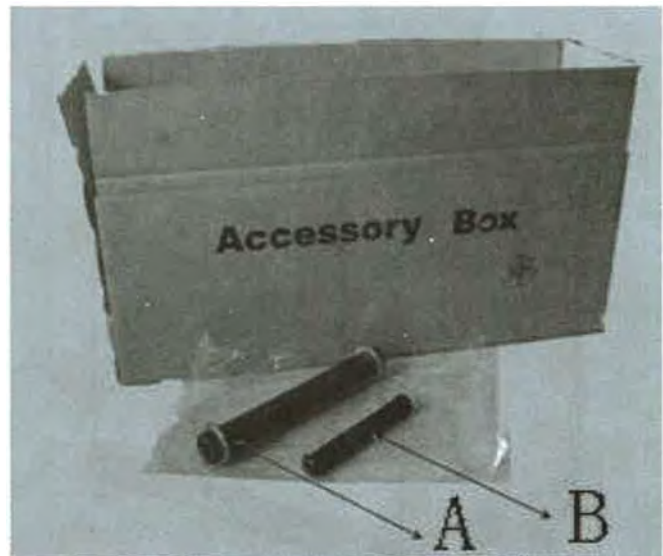

Fig 4-1

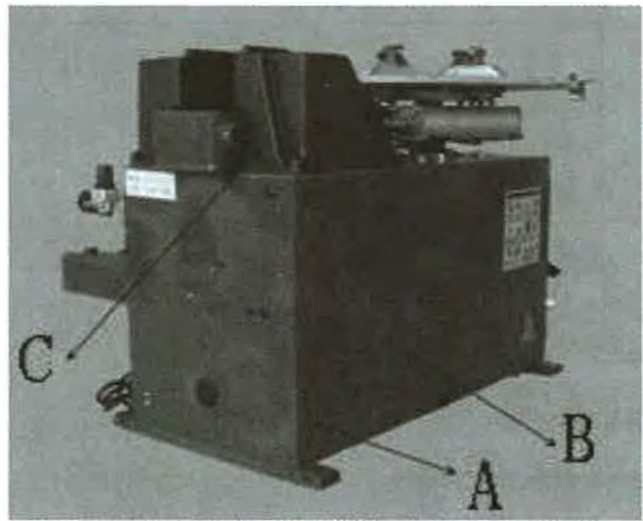

Fig 4-2

4.2.7 Lift up the column and insert the PU hose (Fig4-3 A) at the bottom into the open at the top of the body of the machine (Fig4-3 B) . Adjust the position of the column to align the rotation shaft bushing (Fig4-4 A) with the hole of the rotation shaft base (Fig4-4 B). Take the nut and washer at one end of the rotation shaft assembly (Fig4-1 A) , making the termination of the shaft about 1mm lower than the base frame. Retighten the washer and nut. The tighten torque is 70N·m.

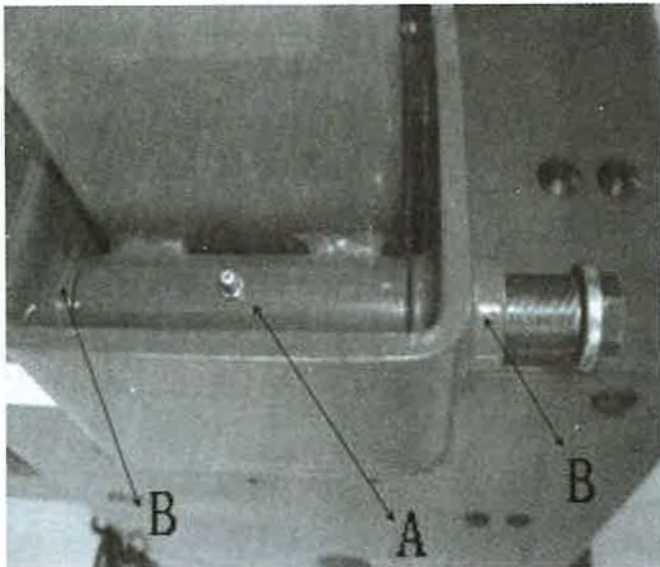

Fig4-3

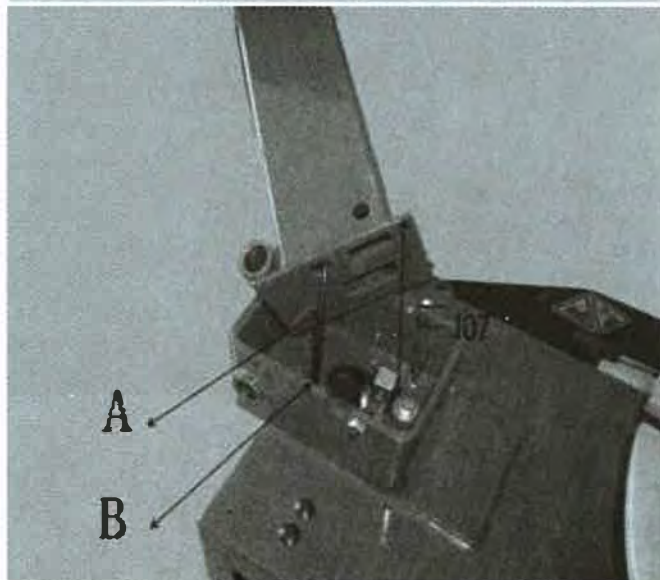
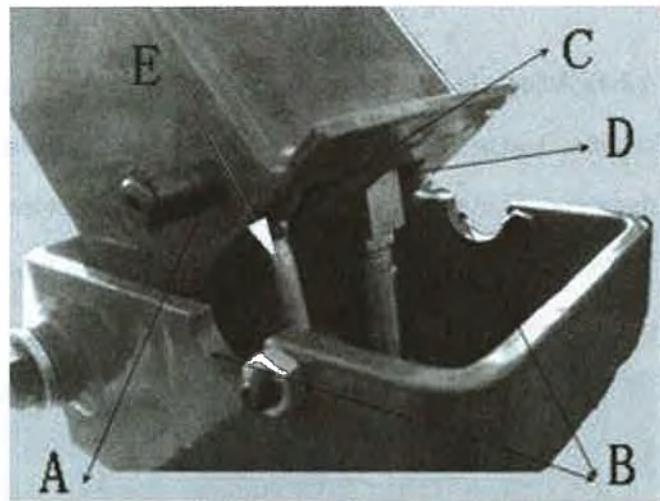

Fig 4-4

4.2.8 Tilt backward the column, cut off the tie of the fix rod (Fig4-5 A) and push out cylinder piston rod

(Fig4-5 B)



Fig 4-5

4.2.9 Position the $\Phi 16$ hole (Fig4-6 A) in front of and below the column at the position of the semi-cycle hole (Fig4-6 B) on the upper seat. Detach the retaining washer on the one side of the push-out shaft (Fig4-1 B) and insert into the corresponding holes of the shaft (Fig4-6E) and cylinder piston rod Fig4-6 D) through the $\Phi 16$ hole and out of from the hole of the other side and then assemble the elastic retaining washer.

Fig 4-6

4.2.10 Assemble the PU hose inserted into the body in the step 4.2.7 into the Tee of the air source hose in the body. (Fig4-7).

4.2.11 Install the horizontal arm protective cover: Remove the cap nut (Fig4-8 A) in the front and the protective fix screw at the back end (Fig 4-8 B) and the fix screw (Fig4-8 D) at the upper end of the vertical cap (Fig4-8 C) and remove the vertical cap.



When detaching the vertical shaft cap, please support the vertical shaft well to prevent the vertical shaft from falling off to injury the person.



Fig 4-7

4.2.12 Remove the package of the protective cover. Twist on the cap nut (Fig4-9 A) and fix screw (Fig4-8 C), Install the vertical shaft spring (Fig4-9 D)、vertical shaft cap and fix screw (Fig4-8 D)、(Fig4-8 C) and fix

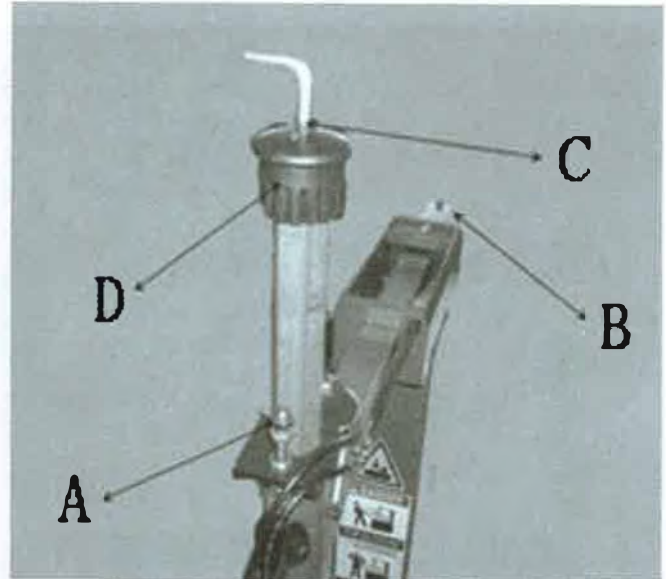
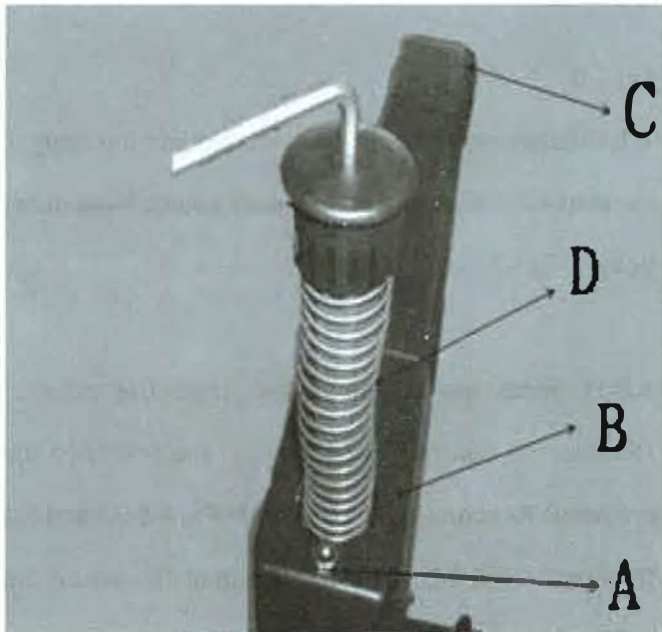

Fig4-8Fig4-9

4.2.13 Adjust the position screw on the two sides of the column: Loose the nuts on the two sides and adjust the gap between the head of the screw and the side of the column to make it to be 0.03mm (Fig4-10) and then lock the nut.

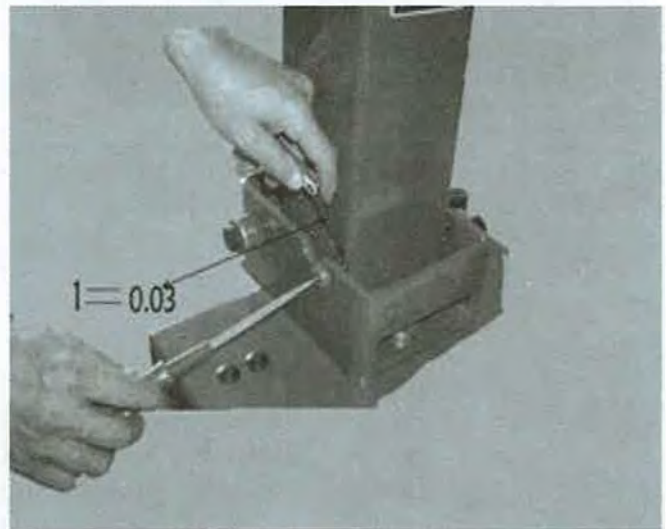

Fig4-10

4.2.14AIR ROUTE TEST:

Connect the air source, use the lock air valve push button to lock the horizontal arm following the fig 2-2. Step the column tilt pedal (fig2-11) and the column

will tilt backwards by about 25 ° . The velocity of the movement of the column has been set to be about 2seconds one stroke. After long time of operation, the speed will become faster or slower, at this moment, you can use the speed adjusting valve to adjust the speed: Loose the nut, twist the screw clockwise, the speed will decrease and counter-clockwise, increase. After adjustment on the screw, you can tight the nut.

4.2.15 Installation of bead breaker blade

4.2.16 Unscrew the lock nut (Fig4-11 B) from the top end of bead breaker cylinder piston rod and unscrew the bolt joint (4-11 F) (4-11 D) on the body. As per the indication in Fig4-11, Insert the blade (4-11 C) into the piston rod (4-11 A), Hang one end of the bead breaker arm spring (4-11 E) on the body and then insert the bolt (4-11 F) into the body and blade hole and use the nut and flat washer (4-11 D) and bolt (4-11 F) to connect and fix. Tighten the lock nut (4-11 B) and bead breaker cylinder piston rod. Hang the other end of the bead breaker arm spring (4-11 E) on the bead breaker arm pin shaft (4-12 A)

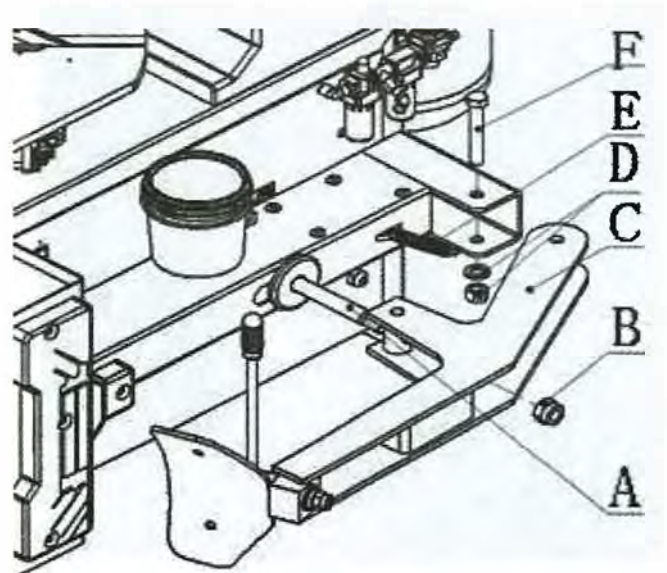

Fig 4-11

4.2.16 Air regulator

Take out the air regulator (Fig4-14 A) from the accessory box and install the air source joint at the inlet of the air regulator (Fig4-13 A) . After installation, insert the air source plug in into the air source joint.

Note: When installation, you should cut off the air source!

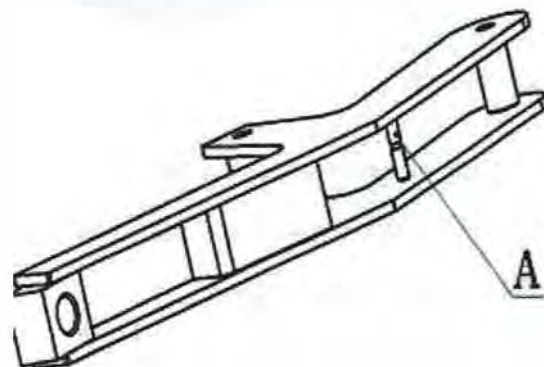

Fig 4-12



Fig4-13

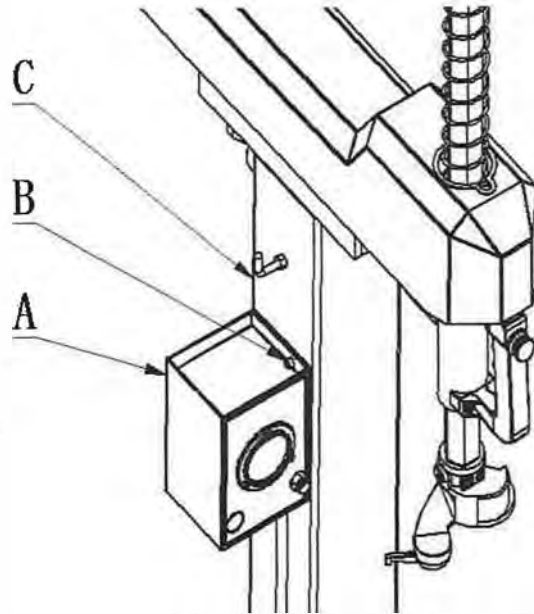



Fig 4-15

4.3 Commission

	<p>All the work related to the electrical must be undertaken by the professional personnel to secure the power supply to be correct and also the phase connect is correct. The improper electricity will damage the motor and without warranty</p>
--	--

Check if the characteristics of your system meet the requirements of the machine. If you have to change the voltage of the machine, please refer to the electrical scheme in Chapter9 to adjust the termination board. Connect the inlet of the air regulator (Fig2-1 S) through the machine with the compressed air system.

	<p>Connect the machine with the electrical system which is equipped with fuse. Perfect grounding should meet the local national standard. When necessary, equip with the electrical leakage protection to secure the safety running of the equipment. If the tire</p>
---	---

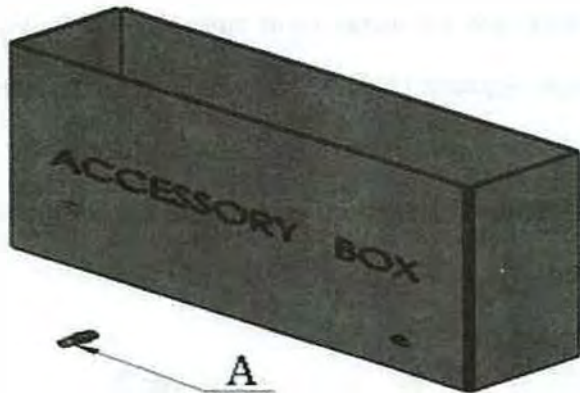

Fig 4-14

4.2.17 Install and connect pressure gauge

Fix the pressure gauge (Fig4-15 A) on the column (Fig4-15 C) by the screw (Fig4-15 B)

4.2.17 Install and connect pressure gauge

Fix the pressure gauge (Fig4-15 A) on the column (Fig4-15 C) by the screw (Fig4-15 B) .

changer not equipped with power plug, the customer should equip one pc. The min. current of the plug should be 16A, meanwhile meeting the relative regulation to the voltage of the machine.

4.4 Operation test

Press down the pedal (Fig4-17 K), turntable will rotate clockwise. Lift up the pedal. Turntable will rotate counter clockwise.



If the turntable does not rotate as per the methods described above, change the 2 wires on the 3-phase connect column.

Press down the pedal H, column U will tilt backwards. Once again press down the pedal, the column will back to the work position;

Press down the pedal I, 4 pcs of clamping jaw will open. Once again press down the pedal, the clamping jaw will close;

Press down the pedal J, bead breaker blade will enter the work condition. Once again blade will go to the original position;

When the handle valve button at the position Y, tool arm U and horizontal arm C will be locked;

When the handle valve button at the position Z, tool arm U and horizontal arm C will be released

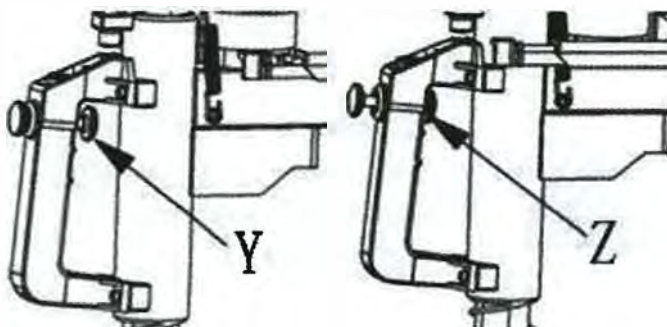

Fig 4-16

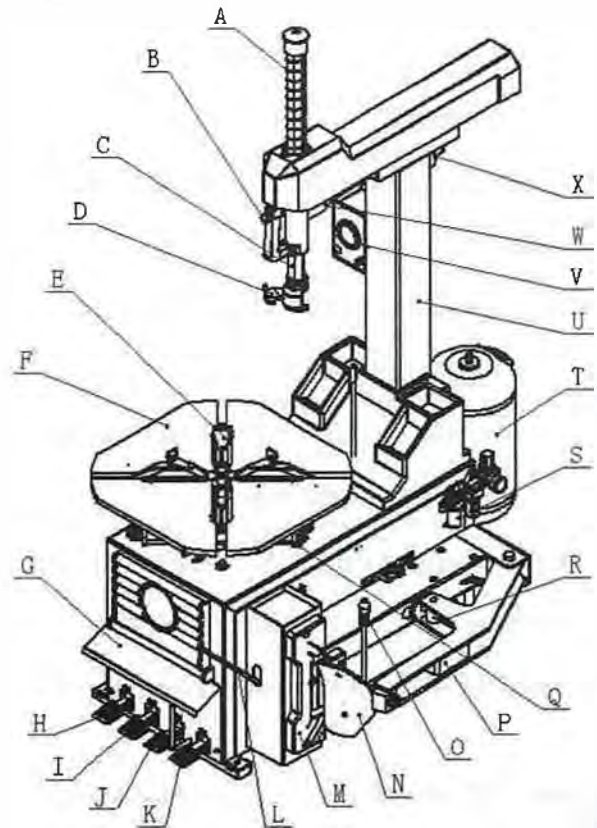

Fig 4-17

Chapter 5 Operation



After read and understand the manual and its warning, you can use the machine.

Before operation, completely deflate the air in the tire and detach all the weights on the tire.

The operation of the tire is composed of

- a) bead breaking b) demounting tire c) mounting tire



We suggest to equip the pressure regulating device.

5.1 Bead breaking



You should be very carefully when breaking bead. When bead breaking pedal

drive the bead breaking arm ship quickly and powerful, the bead breaker arm will be danger to or crush all the things in its stroke area.

Check if the tire is deflated, if not, completely deflate the air in the tire.

Completely close the turntable clamping jaws.



When bead breaking, if the clamping jaw at the open position, it will be very dangerous to the hand of the operator.

Lean the wheel against the wheel support at the right side of the body of the tire changer (Fig5-1 M)

As shown in Fig5-2, lean the bead breaking blade



Make sure the rim is firmly fixed on the clamping jaw.

(Fig5-1 N) against the bead about 1cm from the tire.

Note it is against the tire not the rim.

Press down the pedal (Fig5-1 J), move the blade.



Spread the grease on the bead. Not use of grease will cause the damage to the bead.

When the blade moves to the end of its travel or when breaking the bead, release the pedal and slightly rotate the tire until the tire is completely come off from the rim.

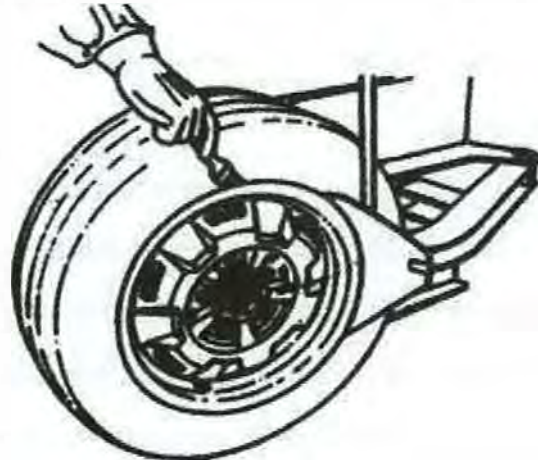
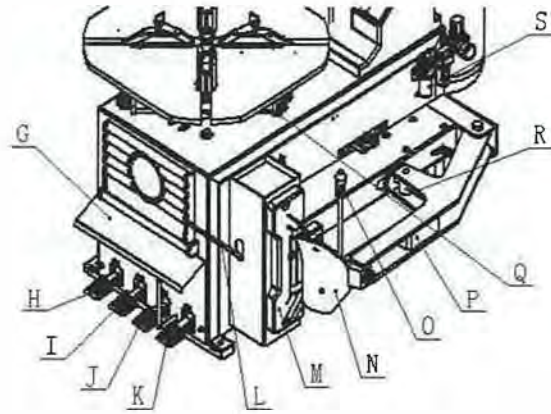

Fig 5-1 Fig 5-2

5.2 Demount tire



Before operation, make sure all the weight has been detached from the tire and check the deflation of the tire.



When the column tilt back, you must secure that nobody is standing behind the tire changer.

Step down the pedal (Fig5-1 H) to tilt down the column for the convenience to clean the turntable.



During locking the rim, never position your hand under the tire. The correct position to fix is the tire is just at the center of the turntable.

<p>Inward clamp</p> <p>Position the tire with the reference to the (Fig2-1 F) and(Fig1-5). Step down the pedal (Fig5-1 I) to the middle position.</p> <p>Position the tire on the clamping jaw and press down the rim, Step the pedal (Fig 5-1 I) to the limit position.</p>	<p>Outward clamp</p> <p>Position the tire with the reference with the position of the clamping jaw (Fig2-1 E)</p> <p>Position the tire on the clamping jaw and press down the rim, Step the pedal (Fig 5-1 I) to open the jaw clamping the rim</p>
---	---

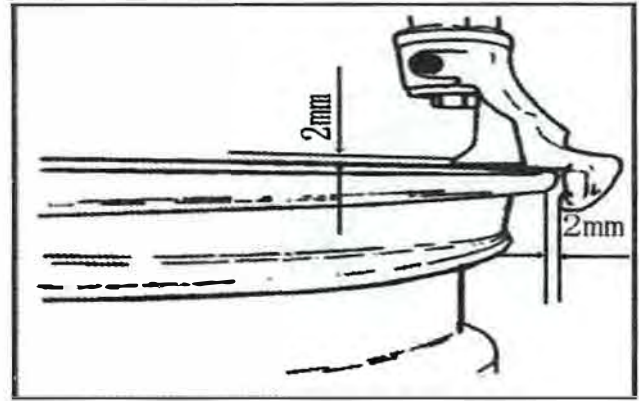

Fig 5-3

Insert the crowbar in between the bead and tool head (Fig5-5) , making the bead move above the tool head.

	<p>Never position your hand on the wheel.</p> <p>The backward of the column to the work position may cause the crush to the hand of the operator for clamped between the tire and rim.</p>
--	--

	<p>Necklace, bracelet, loose clothed and movable parts all can be danger to the safety of the operator.</p>
--	---

Use the crowbar to lift the bead to the position of the tool head (Fig5-4) . Step down the turntable rotation pedal (Fig5-1 K) and the turntable will rotate clockwise until the entire upper bead come out. If demount the tire with tube, to avoid damaging the tube, you should keep the distance from valve to the tool head to be 10cm (Fig5-5);

	<p>To avoid damaging the tube, the valve should at the right side of the tool head.</p> <p>The distance is 10cm (Fig5-5)</p>
--	--

To detach the tube of the tire, step down the pedal (Fig2-1 H) to tilt down the column (Fig2-1 U) and not unlock the tool arm. Repeat this operation one side of bead. (Fig 5-6) .

Step down the pedal (Fig2-1 H)to turn over the column (Fig2-1 U)

Position the lock button at the Y position (Fig4-16 Y) release the lock of tool arm M. Move the tool arm downwards making the tool head over the rim. Position the lock button at the Z position (Fig4-16 Z) lock the whole tool assembly. This lock is composed ofhorizontal/ vertical lock. The distance between the toolhead and rim is 2mm (Fig5-3).

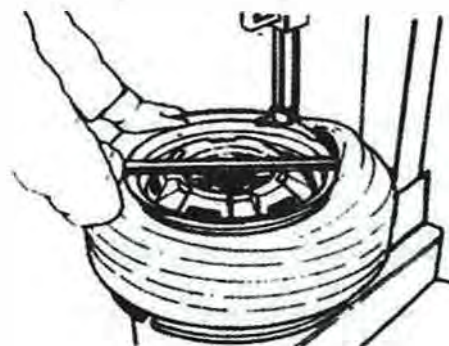

Fig 5-4

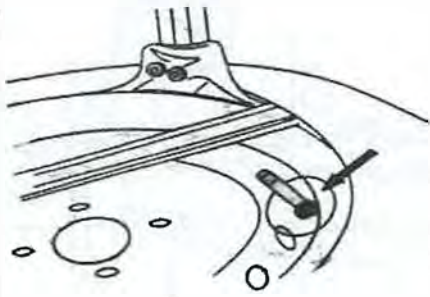

Fig 5-5



Fig 5-6

5.3 Mount tire



The most important is to check the tire and rim to avoid the exploration in the process of inflation. Before mounting tire, you should make sure that:

The thread and tire not damaged, if there is any damage, do not mount the tire.

Not find any dent and pay attention there is not any scratch outside the Aluminum alloy rim. It is very dangerous especially when inflation.

Use the special grease to lubricate the bead to avoid the damage to the bead and make it easy to operate.



When lock the rim, not put your hand

under the tire. The correct operation is to make the tire in the center of the turntable.

Clamping range for 22inch :10-20inch for outward clamping and 12-24inch for inward clamping



Make sure there is none standing behind the column when tilt down the column.



If the size of the rim to be handled is same, not necessary to frequently lock or release the tool arm. The only thing you need to do is to tilt down the column or move it to the work position. Tool arm is kept at the work position.



Do not put your hand on the wheel, for the column will crush the operator's hand in between the rim and tool head when the column back to its work position.

Move the tire making the bead pass under the front end of the tool head, use your hand to press the bead into the groove of the rim, Step down the pedal (Fig5-1 K) making the turntable rotate clockwise. Continue this operation until the tire completely into the rim.



To avoid the industrial accident, the hand and part of your body should be kept away from the tool arm when the turntable is rotating.

Put in the tube and repeat the above operation



When demount/mount the tire, the turntable should rotate clockwise. The

counterclockwise is only used when the incorrect operation.

Chapter 6 Inflation



When inflating, you should be very carefully. Strictly follow the following instruction. For the design and manufacture of the tire changer not protect the persons nearby when the tire suddenly exploded.



Tire explosion may cause the serious damage to the operator and even death. Carefully check is the size of the rim is same to the size of the tire. Before inflation, you should check is there is any fault or wear on the tire. Check the air pressure after inflating. The max. Inflation pressure set up is 3.5bar=51psi. Do not exceed the pressure value the manufacturer suggest and keep your hands and body far from the tire.



Danger of explosion!

It should not exceed 3.5bar (51psi) when inflating. If require relative high pressure, detach the tire from the turntable and place into the inflation cage. Never exceed the pressure the manufacturer suggests. Hand and part of body should be at the rear side of the tire being inflated. Only the professional personnel trained, the others should not operate the machine or at the zone near the tire changer.

6.1 Common inflation procedure:

- ① connect the inflation gauge with the tire valve
- ② Check if the size of tire is corresponding with the size of the rim.
- ③ Check if the bead is fully lubricated. If necessary, continue lubrication
- ④ Inflation. Check the pressure of the pressure gauge
- ⑤ Continue inflation. Check the air pressure while inflating .

6.2 Burst inflation

The burst inflation is very convenient to the tubeless tire inflation.



In this process, the noise may reach 85dB, hence, we suggest to use the noise protection.

- ① Fix the wheel on the turntable, connect the inflation nozzle with the tire valve.
- ② Check if the size of tire is corresponding with the size of the rim.

- ③ Check if the bead is fully lubricated. If necessary, continue lubrication
- ④ Step down the pedal to the middle position.
- ⑤ Inflation. Check the pressure of the pressure gauge and continue inflation. Check the air pressure while inflating until the air pressure reaches the required air pressure.

	<p>Danger of explosion!</p> <p>It should not exceed 3.5bar (51psi) when inflating. If require relative high pressure, detach the tire from the turntable and place into the inflation cage. Never exceed the pressure the manufacturer suggests.</p> <p>Hand and part of body should be at the rear side of the tire being inflated. Only the professional personnel trained, the others should not operate the machine or at the zone near the tire changer.</p>
---	--

Chapter 7 Installation and operation of the assistant arm (assistant arm is the optional)

PL330 (left assistant) and AL335(right assistant) are the important assisting device of the tire changer. They can independently or combined together on the tire changer dealing with the tires with the diameter of more than 20" to help demount and mount the stiff and flat tire to complete the work that only the operator can hardly complete of impossible to complete.

7.1INSTALL THE LEFT ASSISTANT



installation, the power and air source must be

7.1.1 The left and right side of the base plate of body of the tire changer which can handle the tire with the diameter of more than 20" all have the installation hole for the left assistant prepared. Before installation, you can remove the side panel and take off the installation rubber plug.

7.1.2 Detach the package of the PL330assistant. Check the accessory according to the pack list. After confirmation, takeout the base assembly (fig7-1) and remove the screw and washer on it.

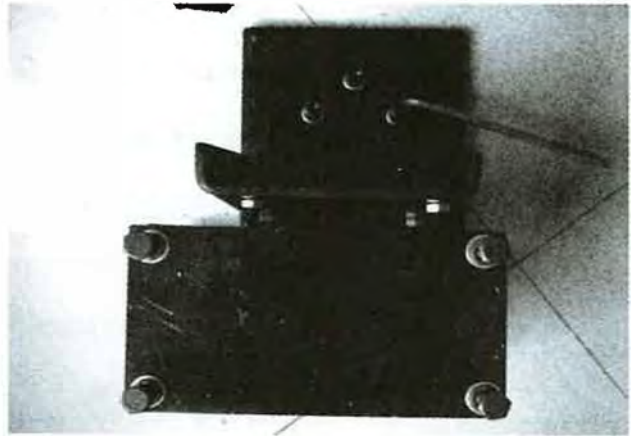

Fig 7-1

7.1.3 Push the platform of the base plate of the base assembly into the body through base plate on the left-back side of the body. Align the thread hole to the reinforce hole and use the bolt and washer to fix. (fig7-2) .



Fig 7-2

7.1.4 Install the body bracket (fig7-3 A) on the seat assembly. Align. Use the screw removed before to fix and not tighten Fig (7-3)

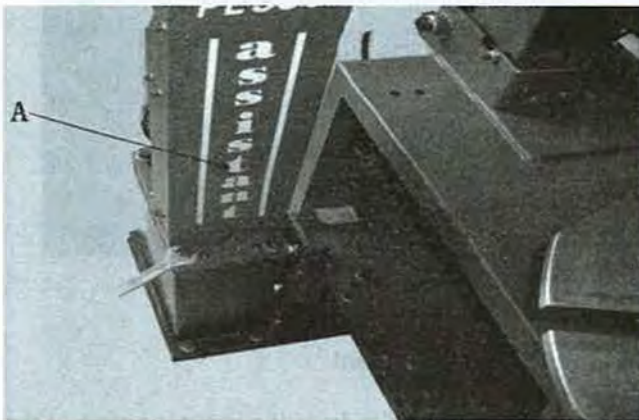

Fig 7-3

7.1.5 Use the fix supporting bracket (Fig7-4 A) to connect the body bracket and the body and insert the screw to fix

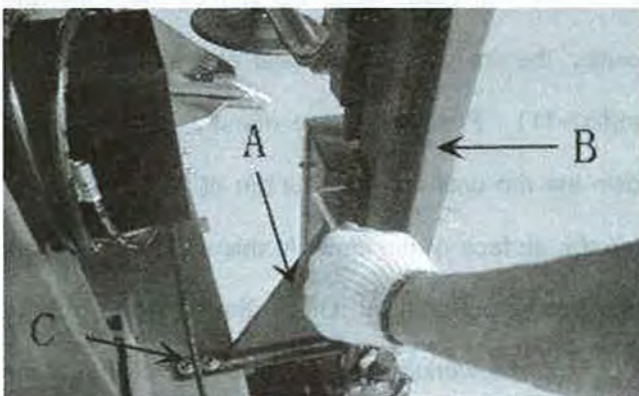

Fig 7-4

7. 1.6 Connect the air source hose and use Y Tee (Fig7-5 A) to connect the outlet hose and the other end connect with the inlet of the assistant pressure adjusting valve.



Fig 7-5

7.1.7 Connect the air source, insert the press cone roller connect rod (Fig 7-6 A) into the rotation shaft hole(Fig7-6 B) of the rotation arm. Handle manual direction change valve to make the tip of the press cone roller coincide to the center of the turntable (Fig7-7) . If not coincide, use the screw to adjust the position of the base(Fig7-4) to realize the coincide. After adjustment, fix the bolt.

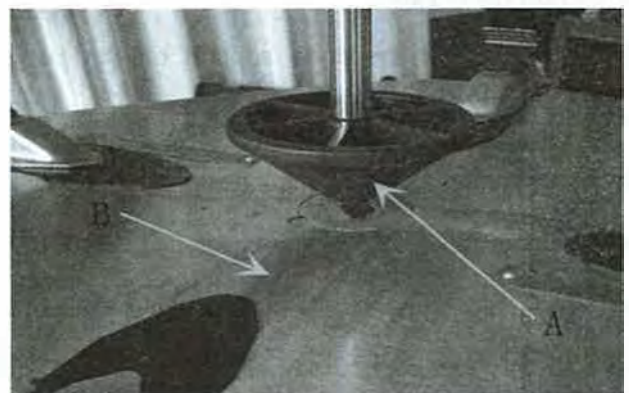

Fig 7-6

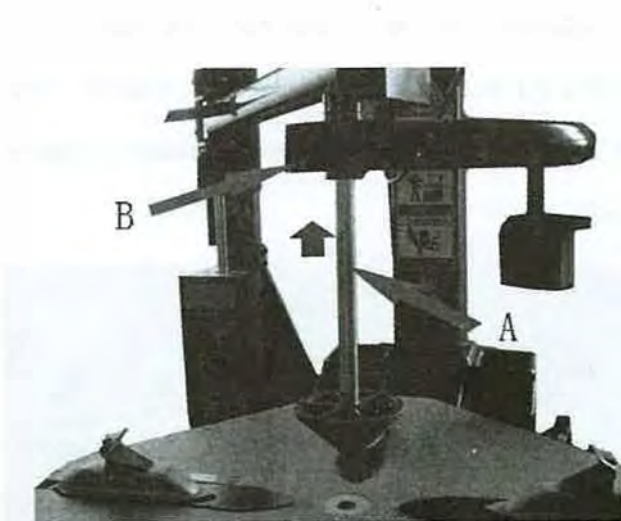

Fig 7-7



Fig 7-8

7.1.8 According to the fig7-8, fix the fix bracket on the body and fix the tool box on the fix bracket and then use the lock nut to tight.

7.1.9 As fig7-9, fix the cone support on the body bracket and install the press cone on the bracket.

7.1.10 Loose the nut below the base and turn the screw clockwise until it against the ground and tight (fig7-10) and install the side panel and tool box removed in the 7.1.1. At this moment, the installation of the left assistant completed.



Fig 7-9



Fig 7-10

7.2 Use of the left assistant

7.2.1 After detach the tire from the rim according to the instruction of the chapter 5, we can execute the following operations.

7.2.2 First, position the claw according to the dimension of the tire and then clamp the rim by the claw and position the tire press cone roller at the center of the rim(fig7-11) . Push down the manual valve to press down the rim until the external rim of the rim is lower than the surface of the claw. At this moment, you can immediately lock the rim. Lift up the support arm and place it at the working position and take off the press cone roller and place it on the support. (fig7-9A)



Fig 7-11

7.2.3 Use the press (fig7-12 A) to press down the tire section by section rim detached from the mouth and use the brush to spread the lubricant on edge of the lip. Position the demount tool head (fig7-12 B) in the demount position. Place the press beside of the demount tool to press down the lip and insert the crowbar below the demount tool in between the rim and lip (fig7-13), Lift up the press and move it to the position opposite to the demount tool and press the lip into the tire detach groove and then rotate the crowbar to lift the lip onto the demount tool (fig7-14). Rotate the turntable to detach the upper lip.

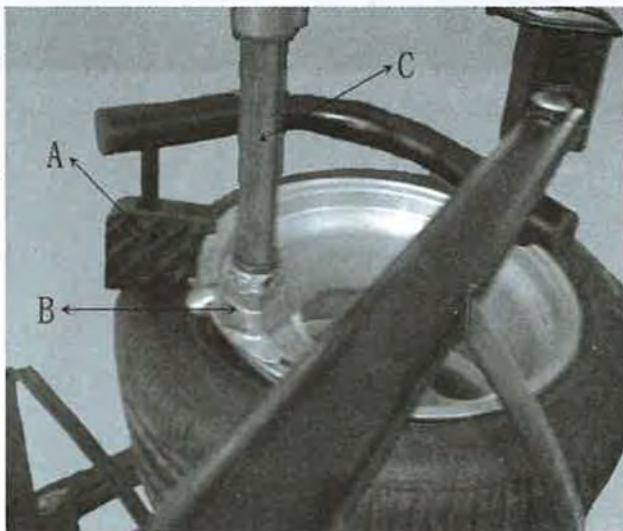

Fig 7-12

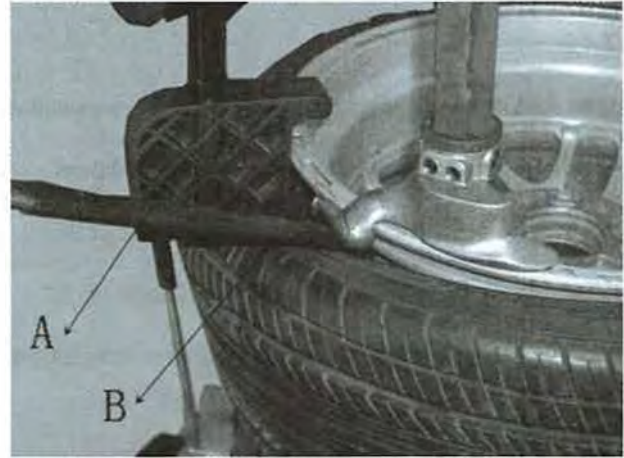

Fig 7-13



Fig 7-14

7.2.4 (Fig7-16) DETACH THE LOWER LIP: Use the disk to lift up the bottom of the tire from the bottom of the mouth (fig7-15) and detach the lower lip (fig7-16) according to the step (5.1.5).

7.2.5 Mount tire



Fig 7-15

First, according to the step (5.2.1) ~ (5.2.3), install the lower lip and use the press to press the lower lip as shown in Fig 7-17. Rotate the turntable by about 90°. And then clamp the press in the demount tool (fig51) and continually rotate the turntable until the completion of the operation.



Fig 7-16



Fig 7-17

7.3 Installation of the right assistant:



must cut off the power source and air source !

7.3.1 Depackage the package carton and check according to the accessory list and the figure 7-18.

Clean up for assembly. The assembly appearance is as shown in the fig7-19. And prepare the required tool.

ACCESSORY LIST:

A fix plate

B screw M10X20 (flat washer) 2sets

C screw M10X25 (nut, flat washer) 2sets

D screw M10X130 (nut, flat washer) 4sets

E ø8PU hose

F ø8 Y-Tee

J base plate

H cushion

I tool box

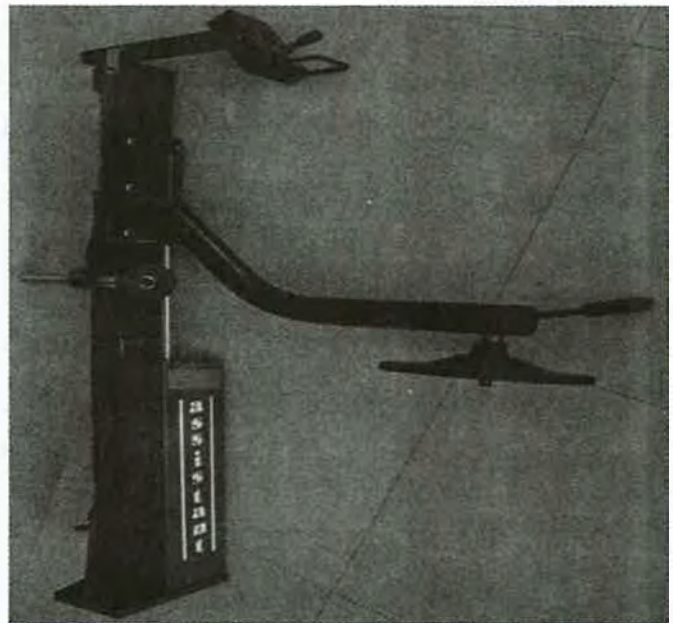

Fig

7-



Fig 7-19

7.3.2First, place the cushion (fig7-18) on the indicated position on the U-steel (fig7-19) to make the 4holes of the cushion aligned.

7.3.3 Upright the body of the assistant on the cushion and use the screw(fig7-18 D) to fix Insert the corresponding screw (fig7-20) , assemble the flat washer and use the nut to tight (fig7-18 J)

7.3.4Remove the hose from the end of the air source fitting and use a small section of the $\varnothing 8$ PU hose to connect the Y Tee with the outlet and another connected with the air source hose (fig7-5)

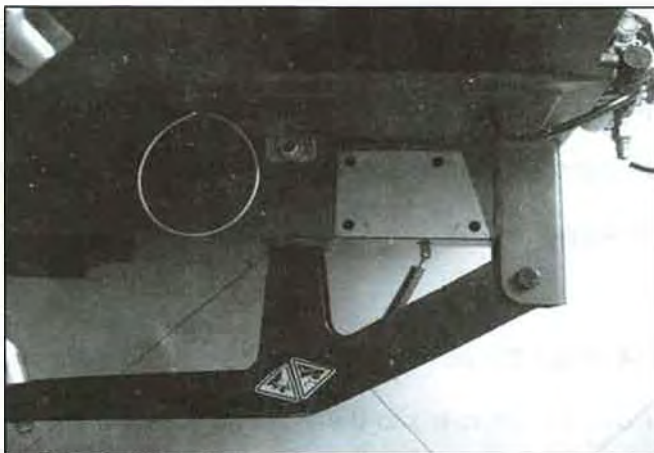

Fig7-2

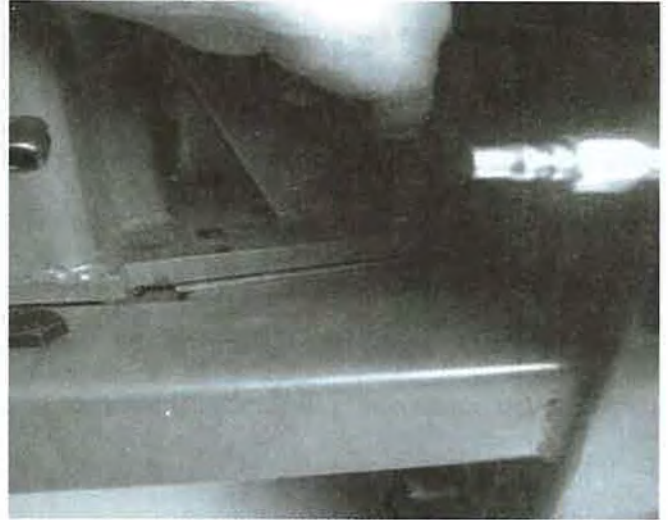

Fig 7-21

7.3.5Insert one end of the $\varnothing 8$ PU hose (fig 7-5) into the idle adapter of the Y Tee and another end connected with the inlet of the pressure adjust valve of the assistant.

7.3.6Use part (Fig7-18 B) to fix the part (Fig7-18 A) on the corresponding position on the assistant column and tighten. Use part (Fig7-18 C)to fix the part (Fig7-18 I)together with the part (Fig7-18) and tighten (Fig7-22)



Fig 7-22

7.3.7Adjust the vertical of the assistant column: According to the situation, you can loose the screw (fig52-5) to adjust the tight screw on the base plate of

the assistant to make the position of the column reach vertical (fig60) . If the column tilt outwards, you should clockwise twist the 2 adjusting screws outside to make the column in the vertical position and if the column tilt inwards, you should clockwise twist the 2 adjusting screws inside to make the column in the vertical position. After adjustment, you should tighten another 4 fix screws.

7.3.8 Connect the air source and push upwards the control valve handle and the assistant movable base will slide upwards. If the handle downwards, the base will downwards. If not exist the phenomenon of air leakage, crawl and climb and normal slide of each p[art, the installation of the right assistant completed.



Fig 7-23

7.4 Use of the right assistant

7.4.1 Prepare according to the normal demount method and clamp the tire on the turntable.

7.4.2 Gradually use the cylindrical press roller to press down the tire and meanwhile rotate the turntable and use the brush to spread the thick soap liquid or the lubricant on between the tire and the rim. (Fig7-24)

7.4.3 Position the column in the working position and fix the demount tool in the required position to demount tire. (as Fig7-25).



Fig 7-24



Fig 7-25

7.4.4 Insert the crowbar into between the tire and rim (Fig7-25) and use the handle valve to lift up the press roller and return Back. Turn over the crowbar to position the lip above the demount head (Fig7-25) . Rotate the turntable clockwise until the entire upper lip detached.

6.4.5 Make the demount head as the support point and insert the crowbar into the lower lip. Use the circular disk to lift up the bottom of the tire to make it move up

until it to the upper edge of the rim (Fig 7-27) and then lower down the disk until ti moves to the un-working position.

7.4.6 Turn over the crowbar to let the down lip rotate upwards until on the demount head (fig65) . Rotate the turntable clockwise until the tire is completely taken out of the rim.



Fig 7-26



Fig 7-27



Fig 7-28

7.4.7 Mount tire

Before mount the tire, you should remove the oil, dust and dirt on the rim. And spread the grease on the upper and bottom bead of the tire. And first mount the bottom bead first. (Fig66).

7.4.8 Position the upper bead above the tail of the tool head and then press the tire press roller on the tire making the upper bead lower than the head of tool head. Clockwise rotate the turntable, after pass the point of 90°, then add the tire press helping device (Fig68) . If it is two helper, you can use left helper to replace the tire press block until to the bead detach groove (Fig68) . And then continue rotate the turntable until the complete tire mounted.

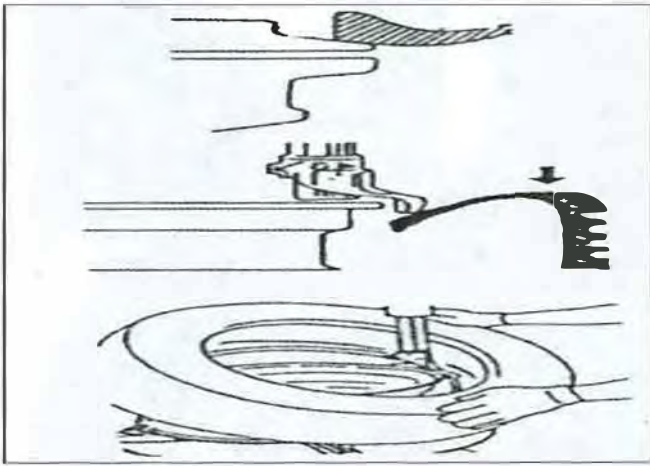

Fig 7-29



Fig 7-30



Fig 7-31

Chapter 8 Maintenance

8.1 Note



The unauthorized personnel is prohibited to execute the maintenance.

The routine maintenance described in the manual is necessary to operate the machine correctly and prolong the life of the machine.

If not maintenance often, it will affect the operation and reliability of the machine and may cause the dangerous to the operators or the others near the dangerous area.



Cut off the power supply and pneumatic source before any maintenance.

It must be the professional personnel to use the original parts to change the parts with fault.

It is prohibited to detach and modify the safety device (valves to limit or change the pressure)



We hereby state that the manufacturer will not hold any responsibility to the damage arising from the use of the spare parts supplied by the other manufacturers or modification of the safety device.

8.2 Maintenance

Weekly clean the turntable using the diesel oil avoiding the existing of the dust. Lubricated the clamping jaw guide rail.

Every 30days, execute the following operations: 25

Check the oil level of the lubrication oil tank. If necessary, release the screw to fill in the oil in the oil tank (Fig 8-1) . Only use the oil of the viscosity ISO VG and grade ISOHG to lubricate the compressed air route.

Check if it will fill one drop of oil when step the pedal for 3-4 times (Fig8-1 I) , if not, use the top screw to adjust (Fig 8-1) .

20days after 1st time of use, retighten the clamping jaw tighten screw (Fig 23) If without force, check if the belt is loose. Detach the driven belt through the adjustment screw on the special motor rack.

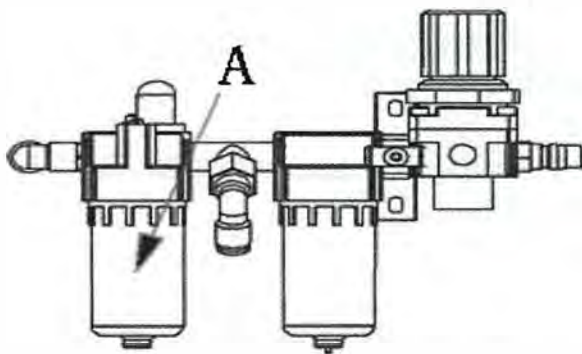

Fig 8-1

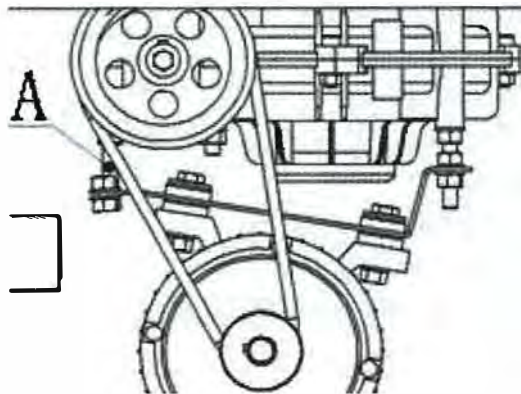

Fig 8-2

8.3 Adjust the clearance between the tool head and rim

8.3.1 Vertical clearance adjustment , adjust the hexangular shaft lock plate:

Shut off the pneumatic source, detach the protection cover of the hexangular shaft. If the clearance is too much, downward adjust the upper and bottom screws at the front end of the hexangular lock plate. If the clearance is too small, upward adjust the upper and bottom screws at the front end of the hexangular lock plate (Fig 8-3A、 B). Connect the pneumatic source and observe the shift after lock

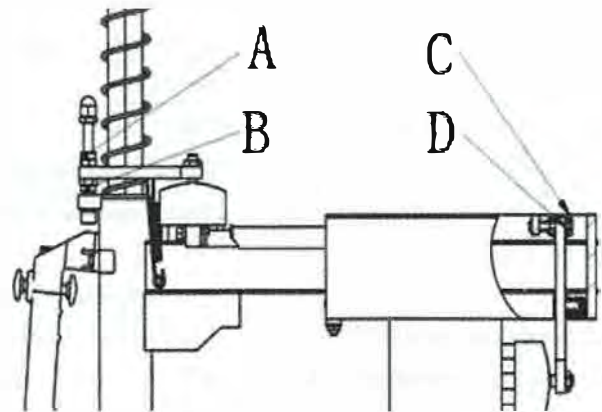

Fig 8-3

8.3.2 Horizontal clearance adjustment, Adjust the quadric lock plate:

Shut off the pneumatic source, detach the protective cover at the upper end of the horizontal arm. Use the spanner to release the lock cup on the M6 screws at two end. Adjust the screw (Fig 8-3 C), meanwhile, use you hand to push the quadric shaft until it moves smoothly (Fig 8-3 B), meanwhile lock the horizontal arm.

Chapter 9 Troubleshooting

TROUBLESHOOTING	REASON	SOLUTION
Turntable rotates in one direction.	Universal switch contact burned	Change Universal switch
Turntable does not rotate.	Belt damage Belt too loose Motor or power source have problems Universal switch contact damage	Change belt Adjust the tension of the belt Check motor, power source and power source cable Change motor if motor burned Change Universal switch
Turntable can not clamp the rim as normal	Claw worn Clamp cylinder air leakage	Change claws Change the air leakage sealing parts
Quadric and hexangular shaft cannot lock	Lock plate not in position Lock cylinder air leakage	Adjust the adjust screw of the lock plate Change the cylinder sealing washer
The horizontal arm fault The vertical movement of the hexangular jamming	The lock position of the quadric lock position not correct The lock position of the hexangular lock position not correct	See Chapter V Adjust the quadric/hexangular lock plate
Column tilt backwards or the return too fast or slow	The deflate of the column cylinder too fast/slow and the air source pressure too slow	Open the side panel and adjust the throttle (3.2.1)
Chassis pedal not return.	Pedal return spring damage	Chang torsion spring
Motor not rotate or the output torque not enough	Drive system jam Capacitor broken down Voltage not enough Short-circuit	Remove the jam Change capacitor Wait for the restore of the voltage Remove
Cylinder output force not enough	Air leakage Mechanic fault Air pressure not enough	Change sealing parts Remove the fault Adjust the air pressure to meet the requirement

Chapter 10 Electrical and pneumatic scheme

220V Electrical scheme

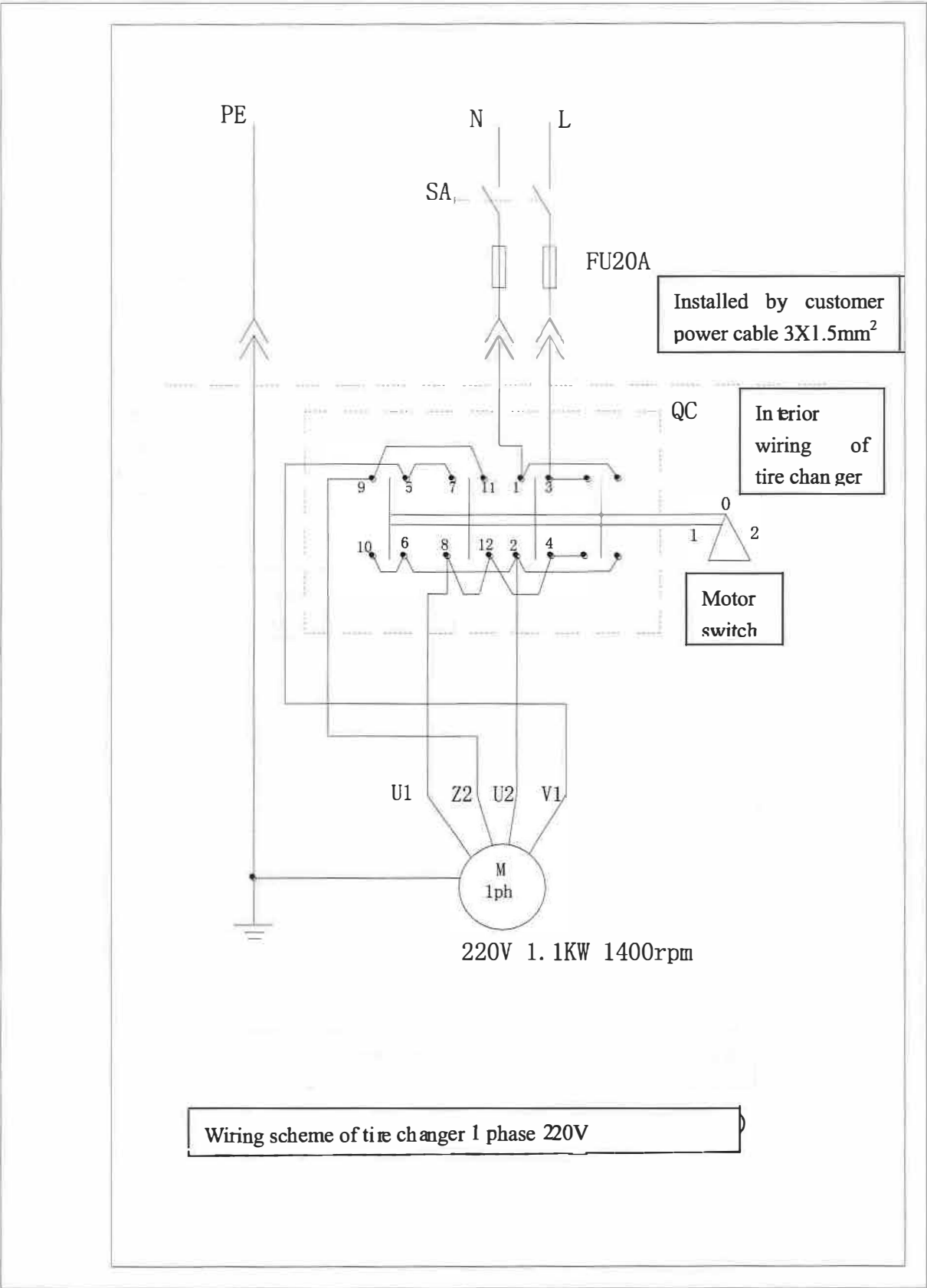

380V Electrical scheme

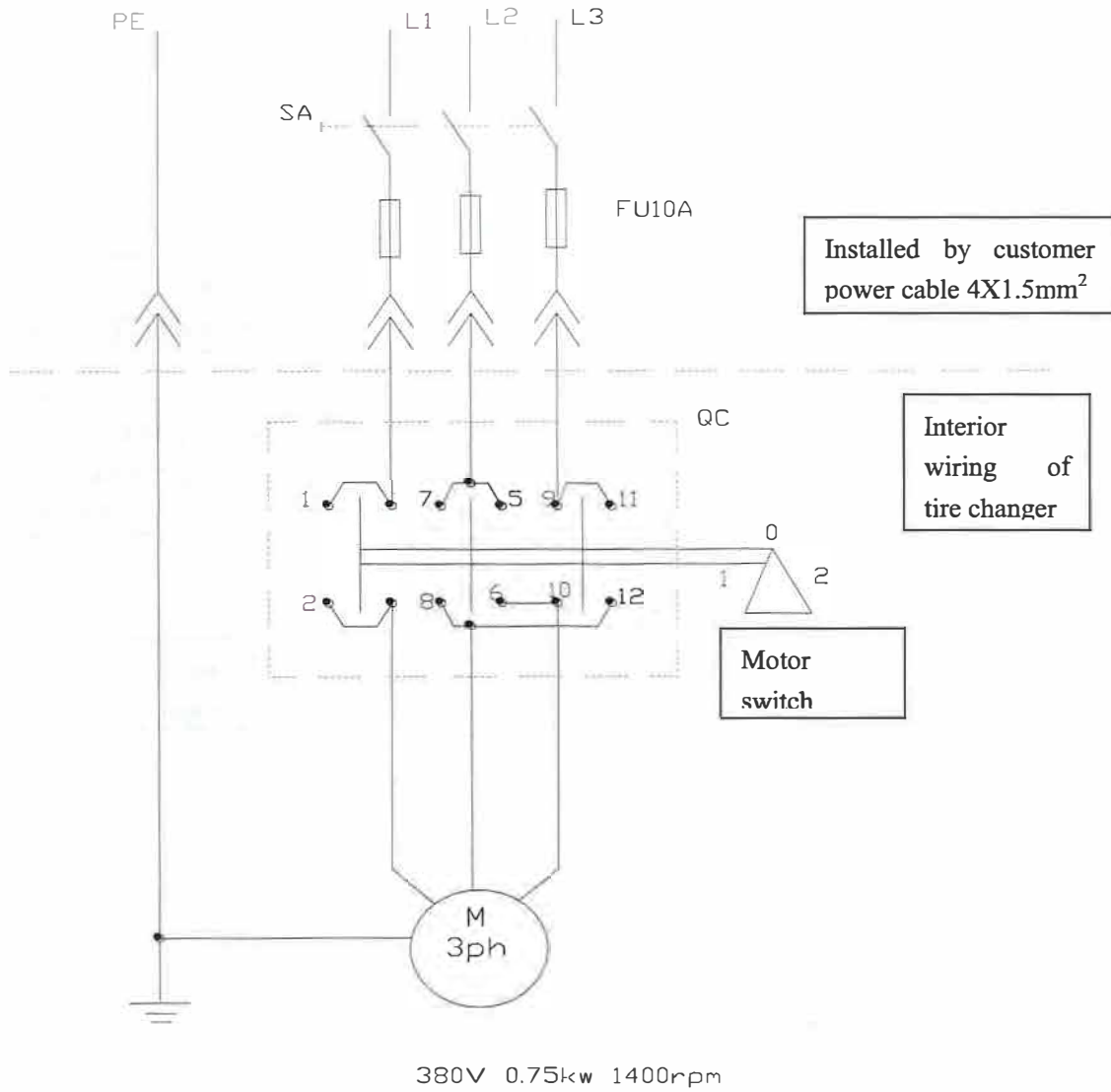

Wiring scheme of tire changer 3 phase 380V

110/220V Electrical scheme

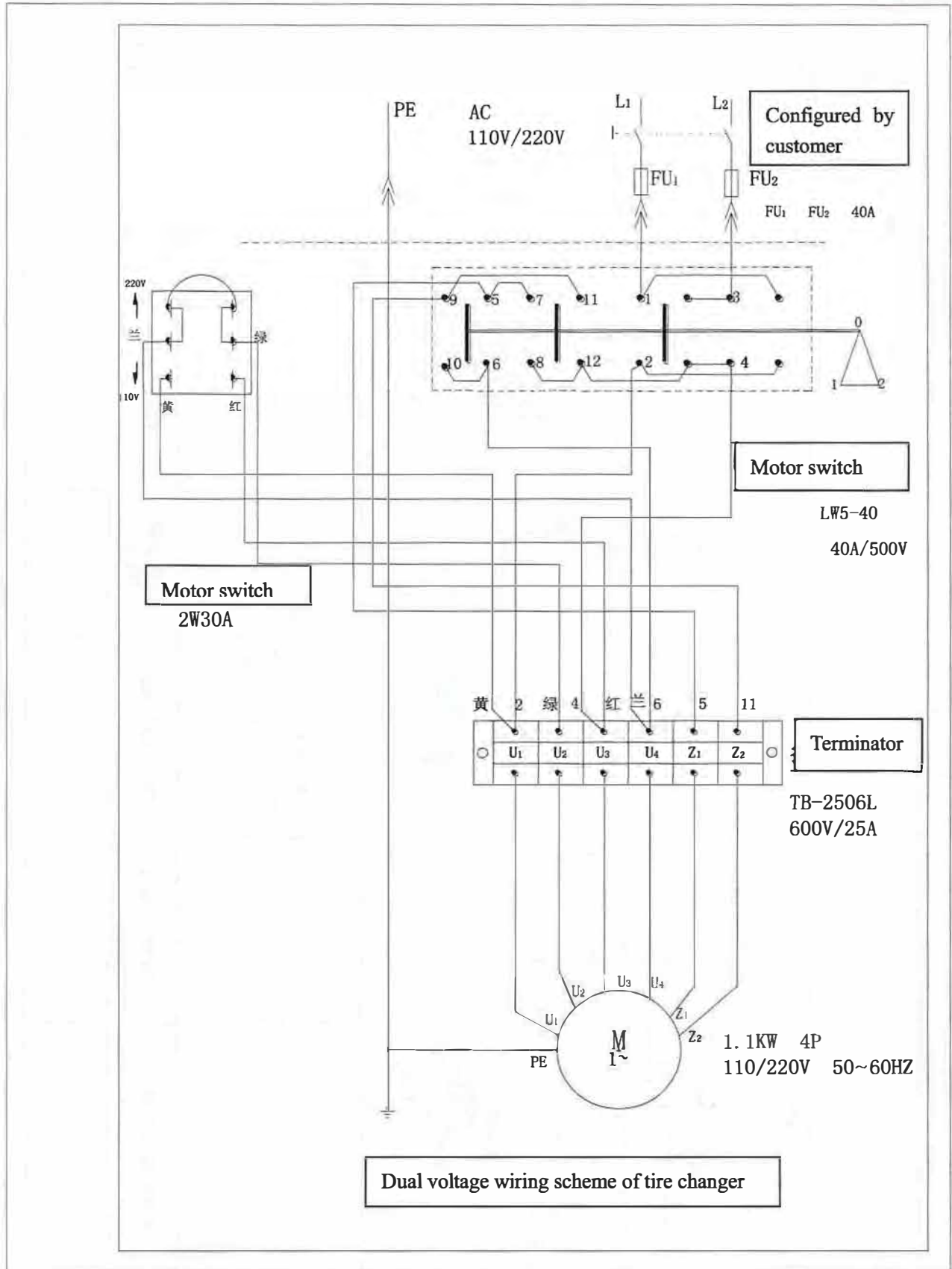

0	1	2	3	4	5	6
FILTER- GROUP	TILTING	LOCKING RIMS	BEAD BREAKER	ARM LOCKING	TIRE GAUGE	BEAD SEATER
RISE DESCENT	OPEN CLOSED	OPEN CLOSED	LOCKING DECHUCKING			

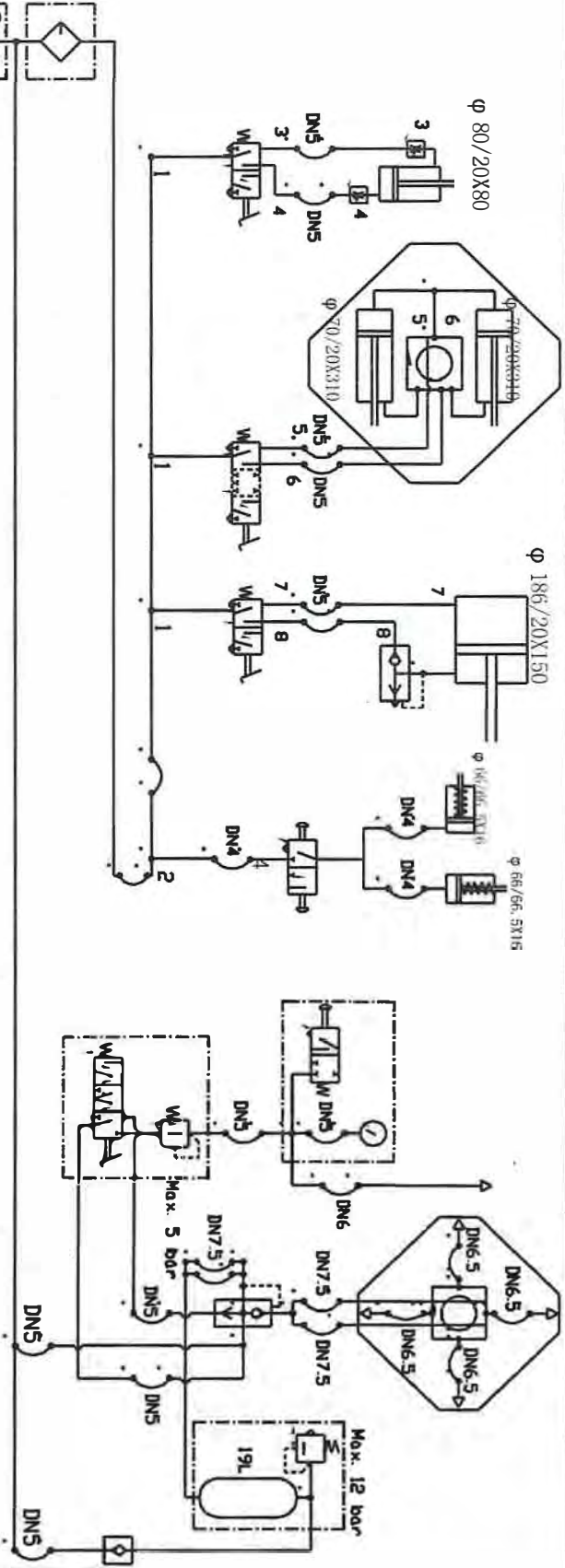

Pe 8/10 bar

885IT PNEUMATIC SCHEMATIC DIAGRAM



Daytona Automotive Equipment
101 Applewood Dr
Brighton ON
K0K1H0
1-866-219-9991
613-475-5400