



CITY OF INDUSTRY, CA  
BROOKSHIRE, TX  
BOLINGBROOK, IL  
JERSEY CITY, NJ  
POOLER, GA  
TEL: 888-636-1918  
EMAIL: [INFO@AUTOKATO.COM](mailto:INFO@AUTOKATO.COM)  
[WWW.KATOOLAUTOEQUIP.COM](http://WWW.KATOOLAUTOEQUIP.COM)



Read the entire contents of this manual before using this product. Failure to follow the instructions and safety precautions in this manual can result in serious injury or death. Make sure all other operators also read this manual. By proceeding with setup and operation, you agree that you fully understand the contents of this manual and assume full responsibility for product use.

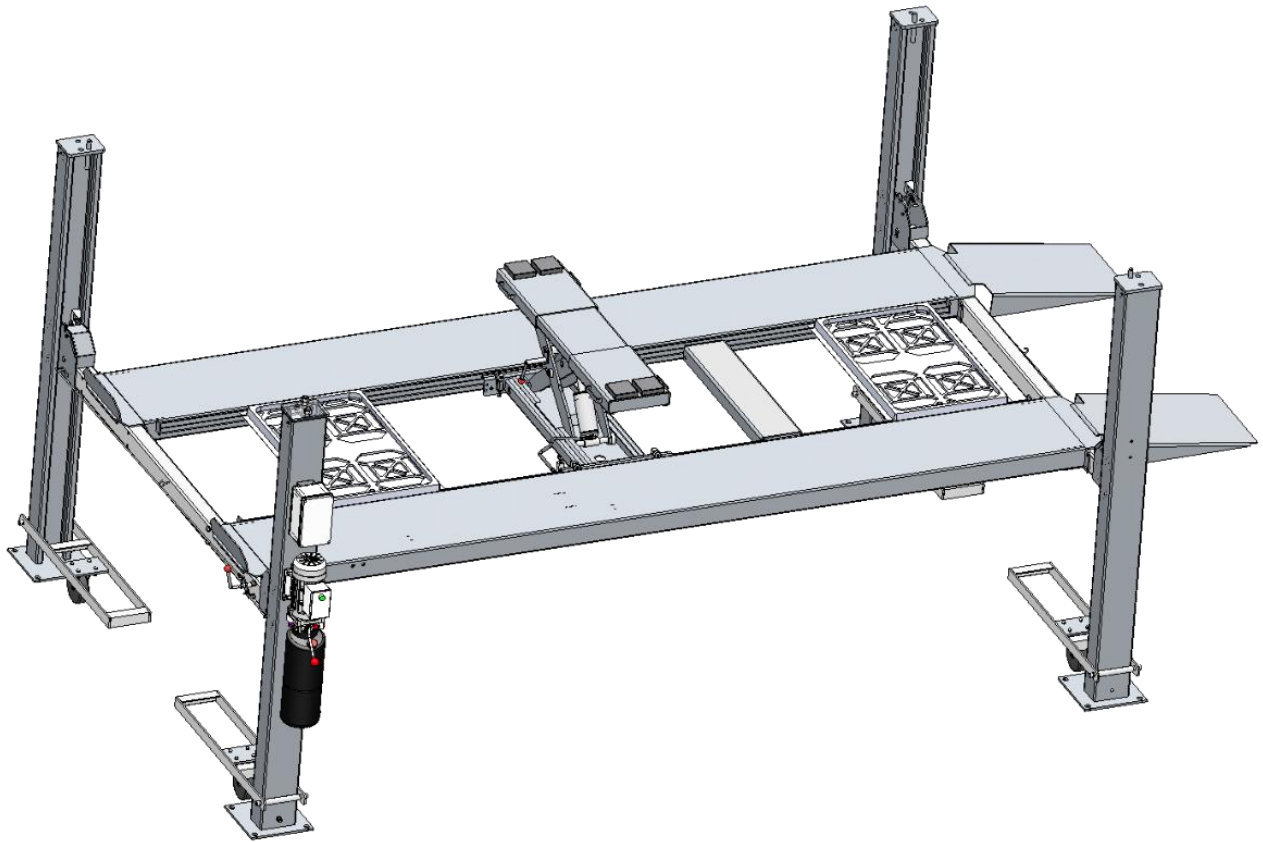
# CONTENTS

I. Product Features and Specifications.....	1
II. Installation Requirement .....	2
III. Steps of Installation.....	3 -23
IV. Exploded View.....	24-32
V. Test Run.....	33

# I. PRODUCT FEATURES AND SPECIFICATIONS(See Fig. 1)

## 4-POST MODEL A435-P FEATURES

- Single point manual safety release.
- Four mechanical locking devices, each equipped with both primary and secondly safety locks.
- Powerside column can be installed at both side, front or rear.
- Non-skid diamond platforms and adjustable safety lock ladders.
- Optional kits: Sliding jack with hand pump, Mobile set, Jack tray



**Fig.1**

Lifting Capacity	Lifting Height	Lifting Time	Overall Length (Inc. Ramps)	Overall Width	Width Between Columns	Gross Weight	Motor
4.3T (9500lbs)	2050mm (80.70")	90S/ 40S	5460mm (214.96")	3100mm (122.04")	2525m (99.40")	962kg	110v/220V/380V

## II. INSTALLATION REQUIREMENT

### A. TOOLS REQUIRED(See Fig. 2)

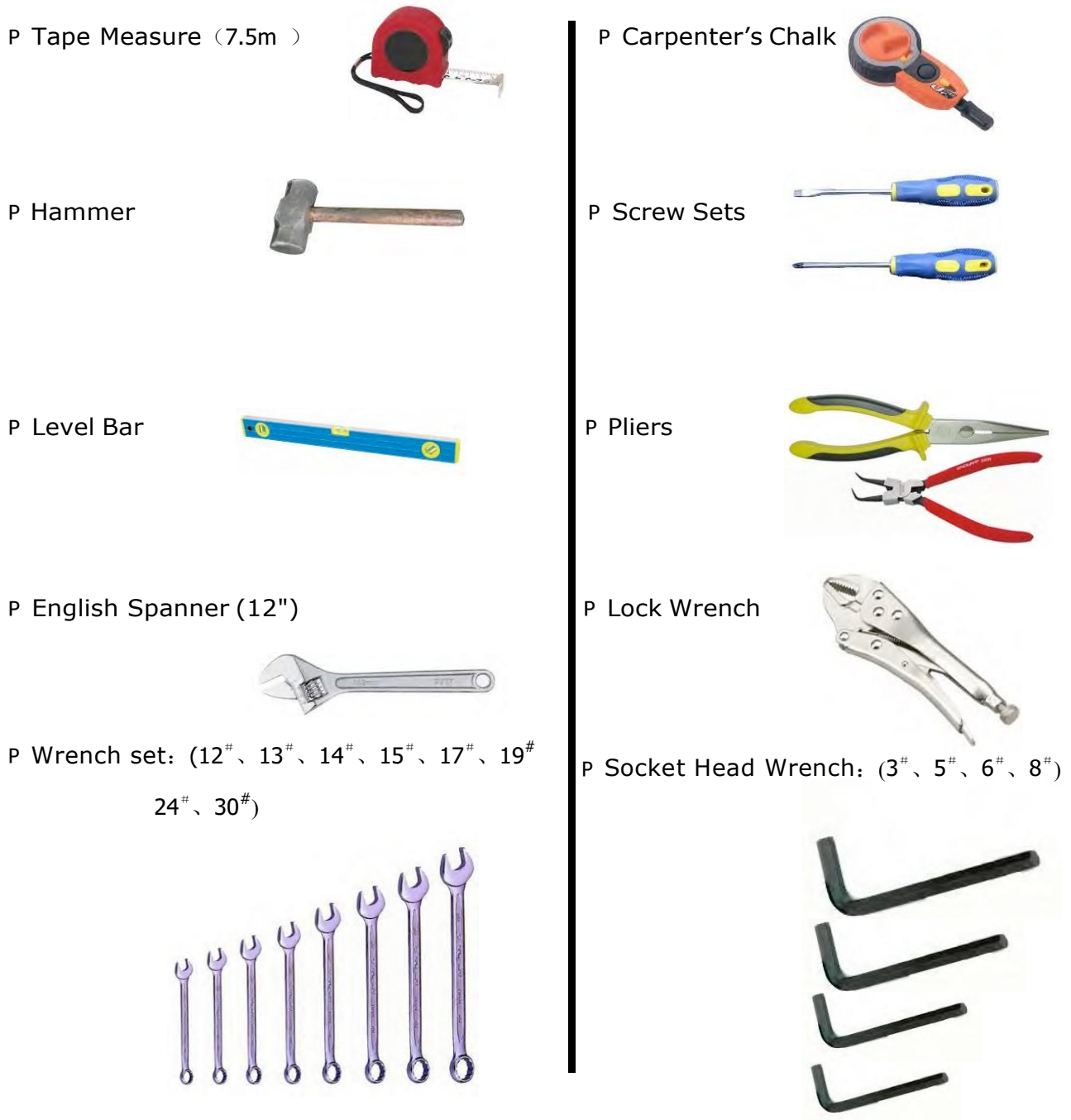


Fig.2

### B. SPECIFICATIONS OF CONCRETE (See Fig. 3)

**Specifications of concrete must be adhered to the specification as following.**

**Failure to do so may result in lift and/or vehicle falling.**

1. Concrete must be thickness 100mm minimum and without reinforcing steel bars, and must be dried completely before the installation.

2. Concrete must be in good condition and must be of test strength 3,000psi (210kg/cm<sup>2</sup>) minimum.
3. Floors must be level and no cracks.



**Fig. 3**

Concrete must be of test strength  
210KG/c m<sup>2</sup>.

### **C. POWER SUPPLY**

The electrical source must be 2.2KW minimum. The source cable size must be 2.5mm<sup>2</sup> and in good condition of contacting with floor.

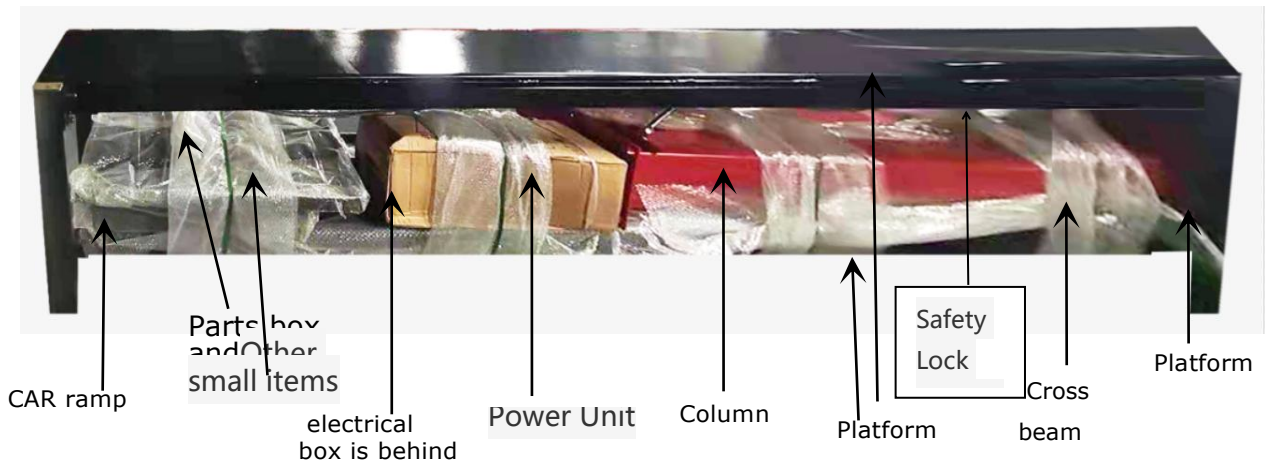
## **III. STEPS OF INSTALLATION**

### **A. Check the parts before assembly**

1. Packaged lift and Hydraulic Power Unit (See Fig. 4).



2. Open the outer packing carefully(See Fig. 5).



**Fig.5**(Note: Parts may be located in different parts in different batches)

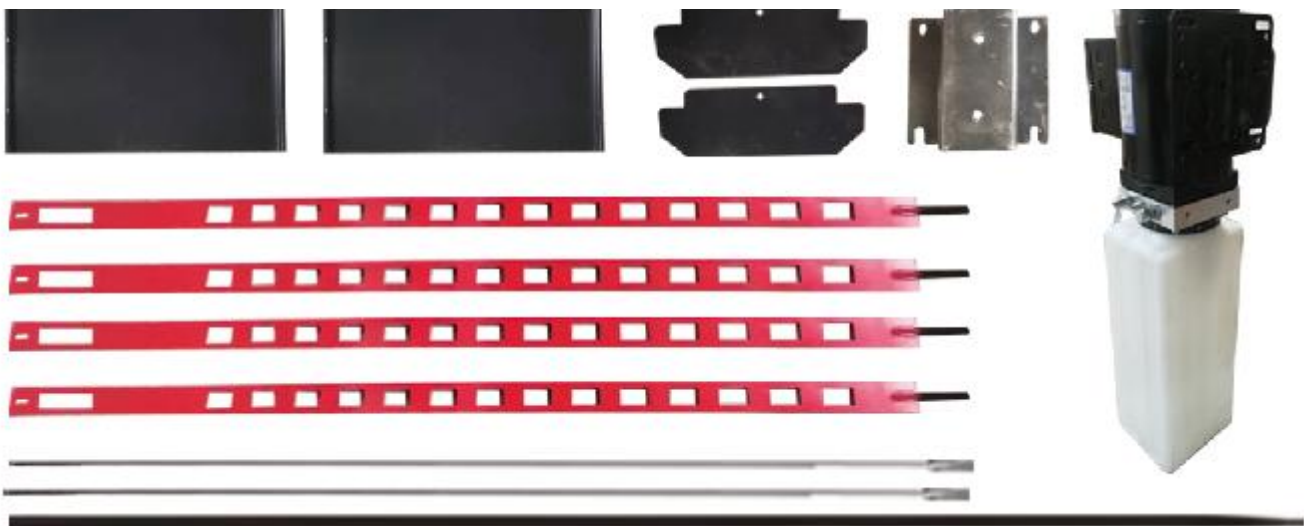
3. Take off the drive-in ramps and The platform above **(See Fig.6)**.



**See Fig.6**

4. Loosen the screws of the upper package stand, take off the offside platform, take out the parts inside the pack, then remove the package stand.

5. Move aside the parts and check the parts according to the shipment parts list **(See Fig. 7-See Fig. 8)**.

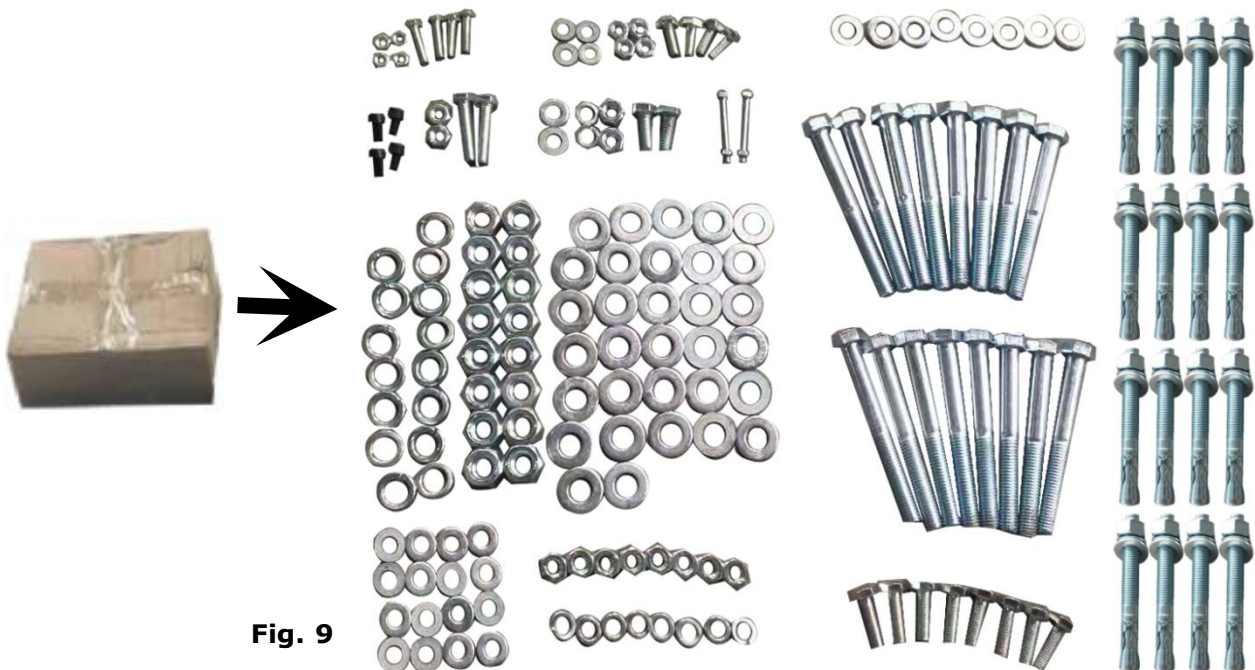


**Fig.7**



**Fig.8**

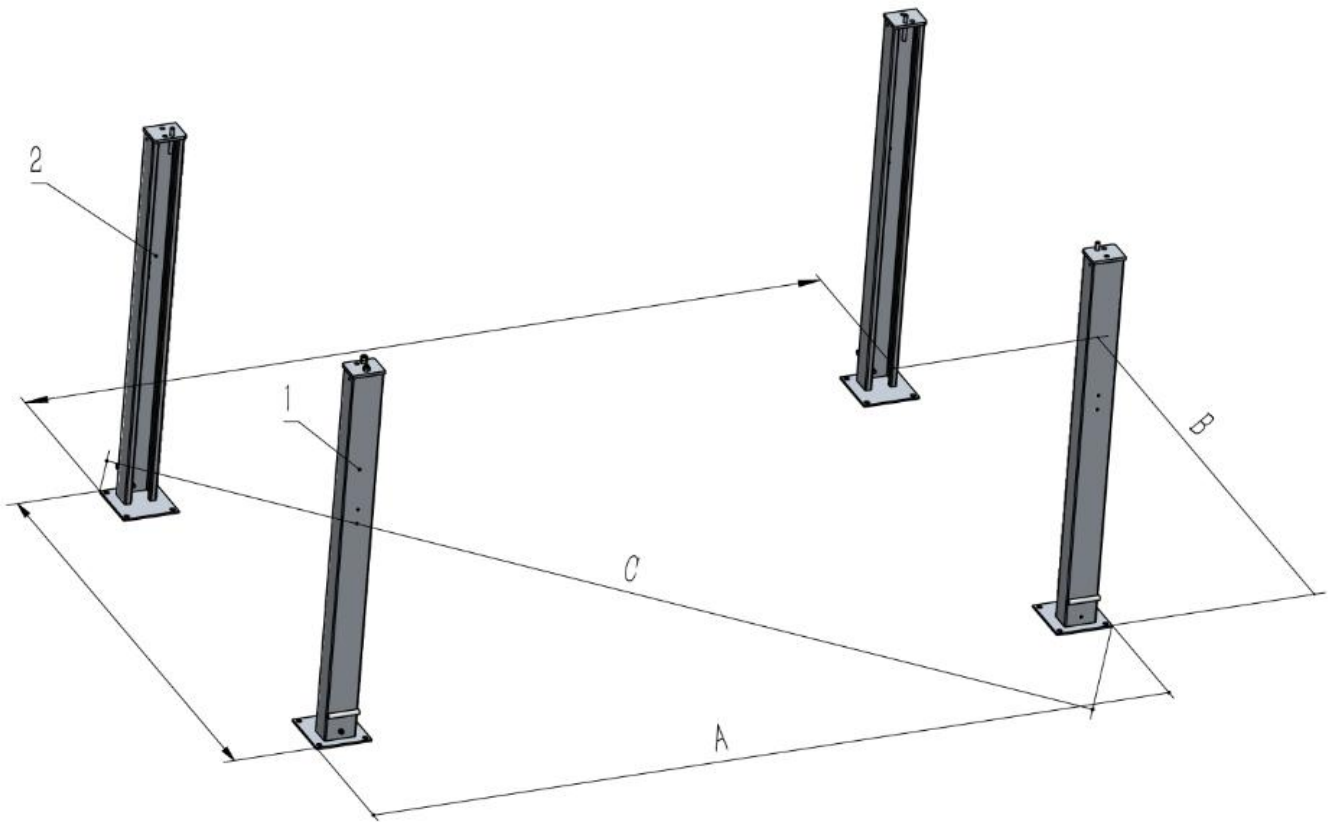
6. Check the parts of the parts bag (See Fig. 9).



**Fig. 9**

**B.** Use a carpenter’s chalk line to establish installation layout as per Table 1  
 Make sure the size is right and base is flat (**see Fig. 10**).

**Note: Reserve appropriate space in front and behind the installation site.**



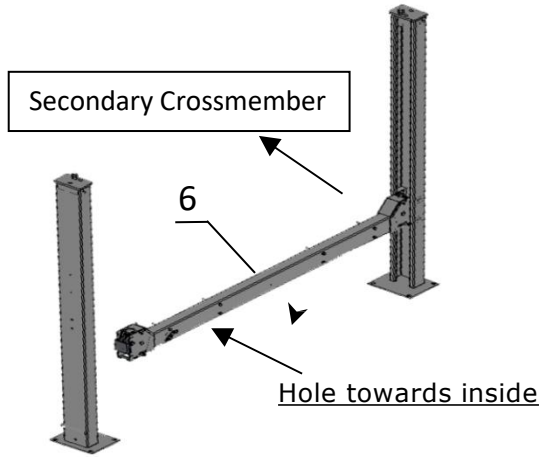
**Fig. 10**

	<b>A</b>	<b>B</b>	<b>C</b>
4.3T	4805mm	2863mm	5593mm
4.3T	189.17"	112.71"	220.19"

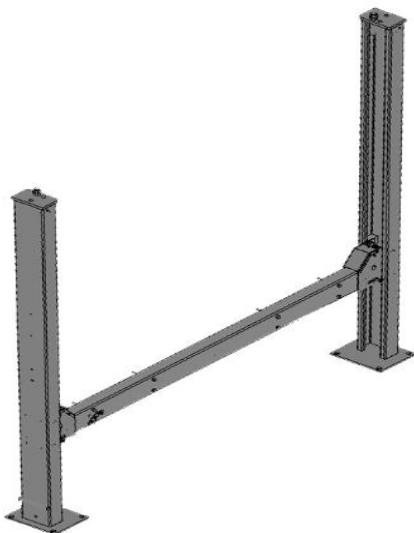
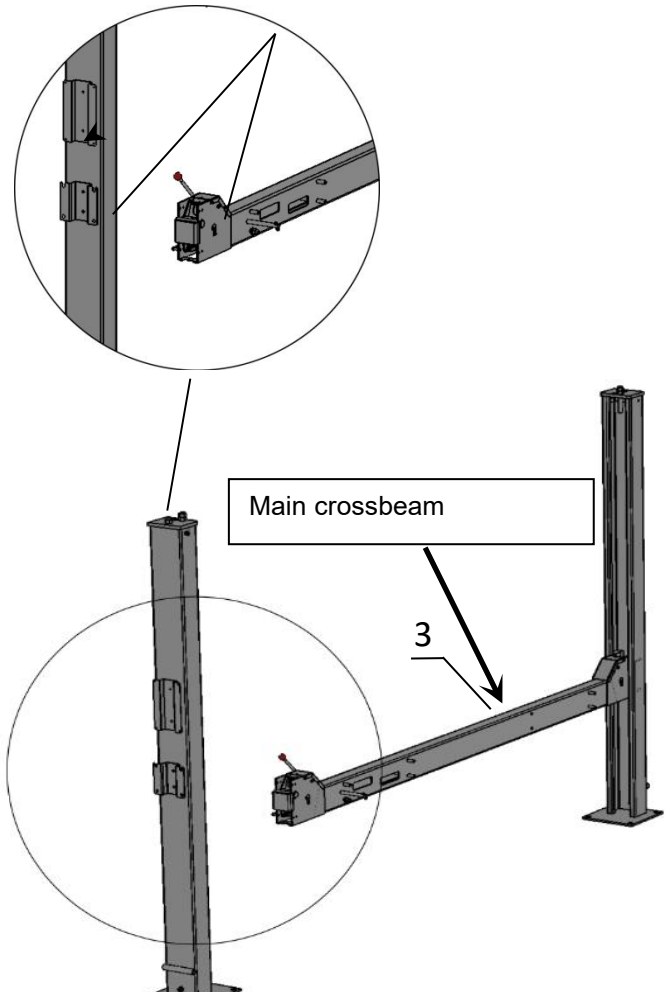
**C. Install cross beams (See Fig.11, Fig.12).**

Note: Pay attention that the cross beam's slot should be positioned towards inward and the safety locks connecting assy. should be adjacent to the power unit column.

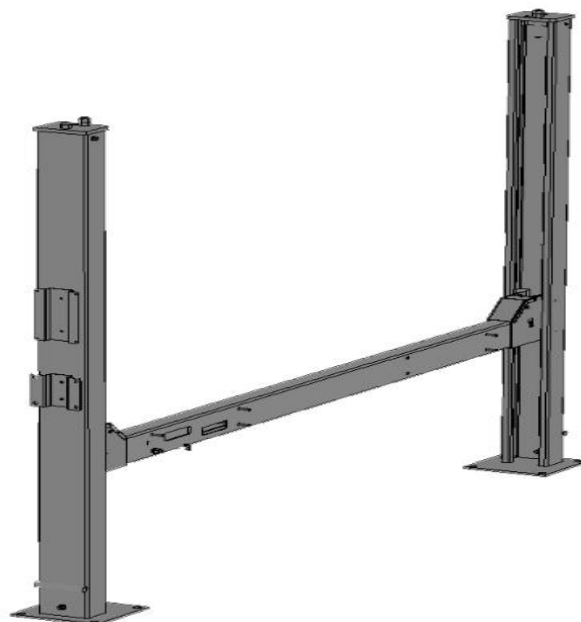
The powerside column need to be installed according to the installed position of the safety lock release handle.



**Fig.11**

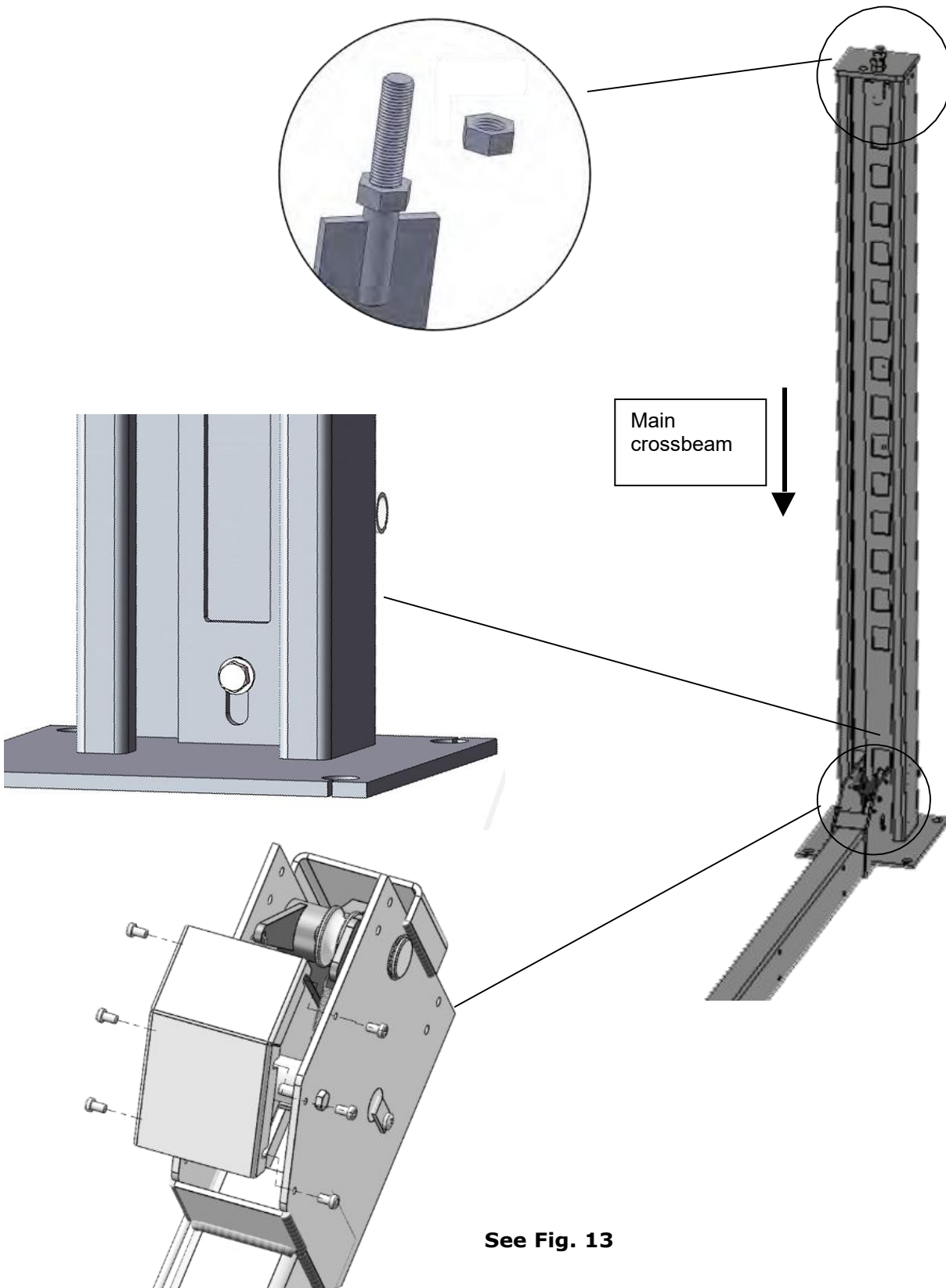


**Fig.12**



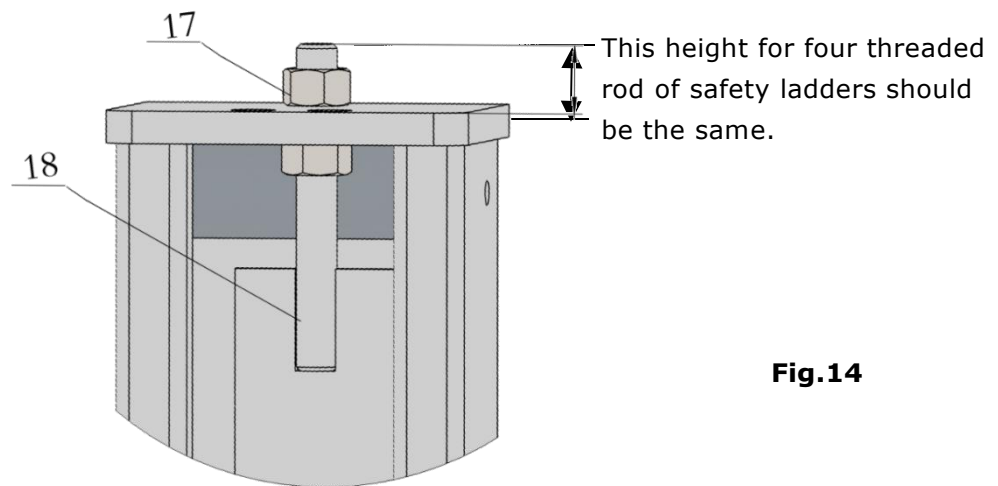
#### D. Install the Safety Ladders.

1. adjust the four lower nuts so they are at the same position. Then insert the safety ladder  
(See Fig. 13).



See Fig. 13

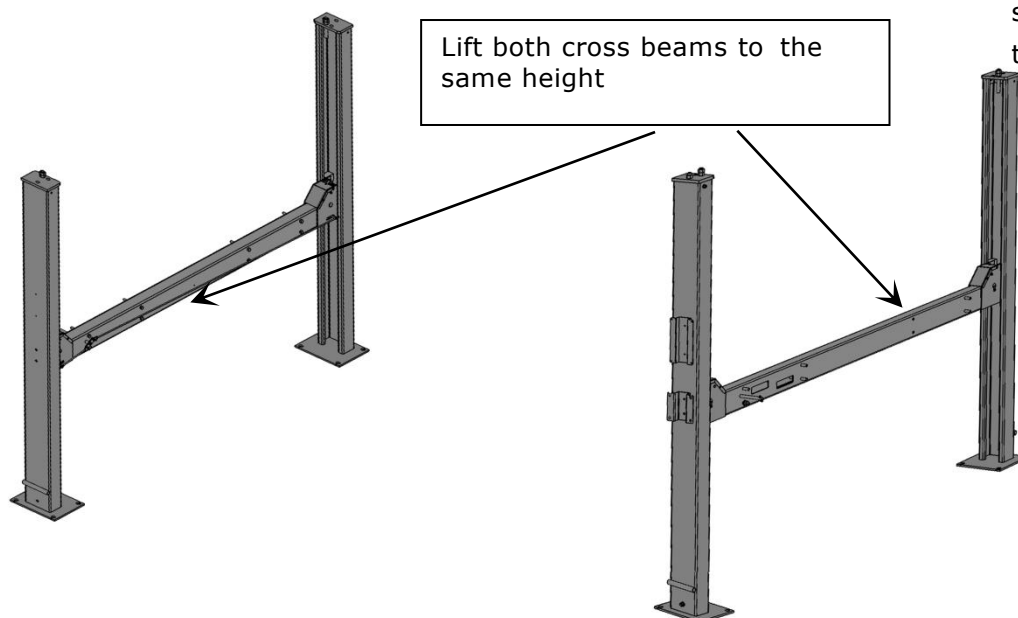
2. Install Safety Ladders (See Fig. 14)



**Fig.14**

Safety ladder pass through the hole of the top plate, then tighten the two nuts

**E. Raise the cross beams at the same height and lock them on the safety ladders (See Fig. 15).**



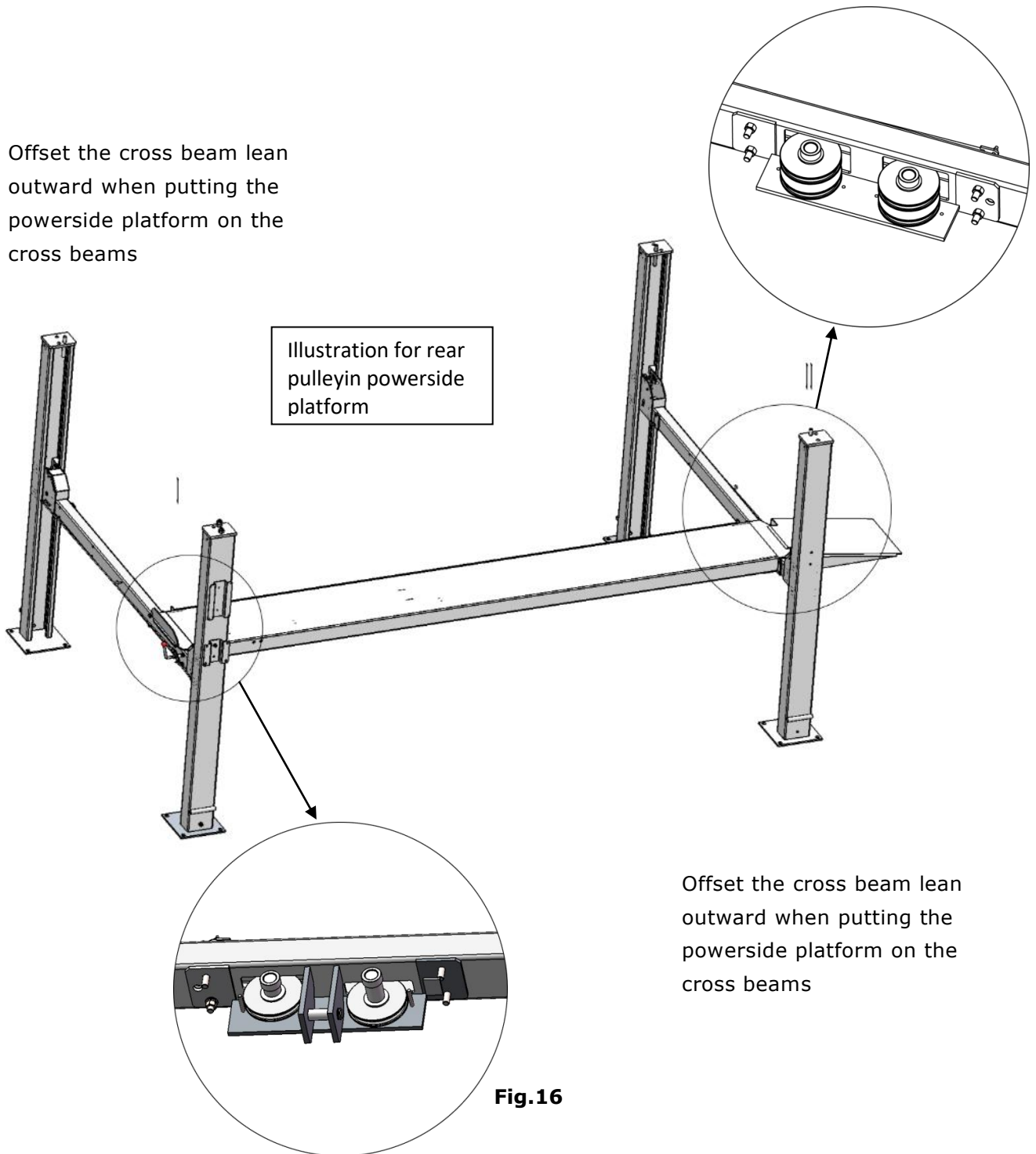
The lifting cross beam height should be fitted for installing the platform and its parts . 1m height is recommended.

**Fig.15**

## F. Install power side platform.

1. Raise the powerside platform above the cross beam by a forklift or crane. Then move the cross beam outwards until the pulleys of both platforms can be rested into the cross beams' slots ( see **Fig.16** ). Tighten the Powerside Platform to the Cross beams by using bolts.

Offset the cross beam lean outward when putting the powerside platform on the cross beams



**Fig.16**

Illustration for front pulley in powerside platform

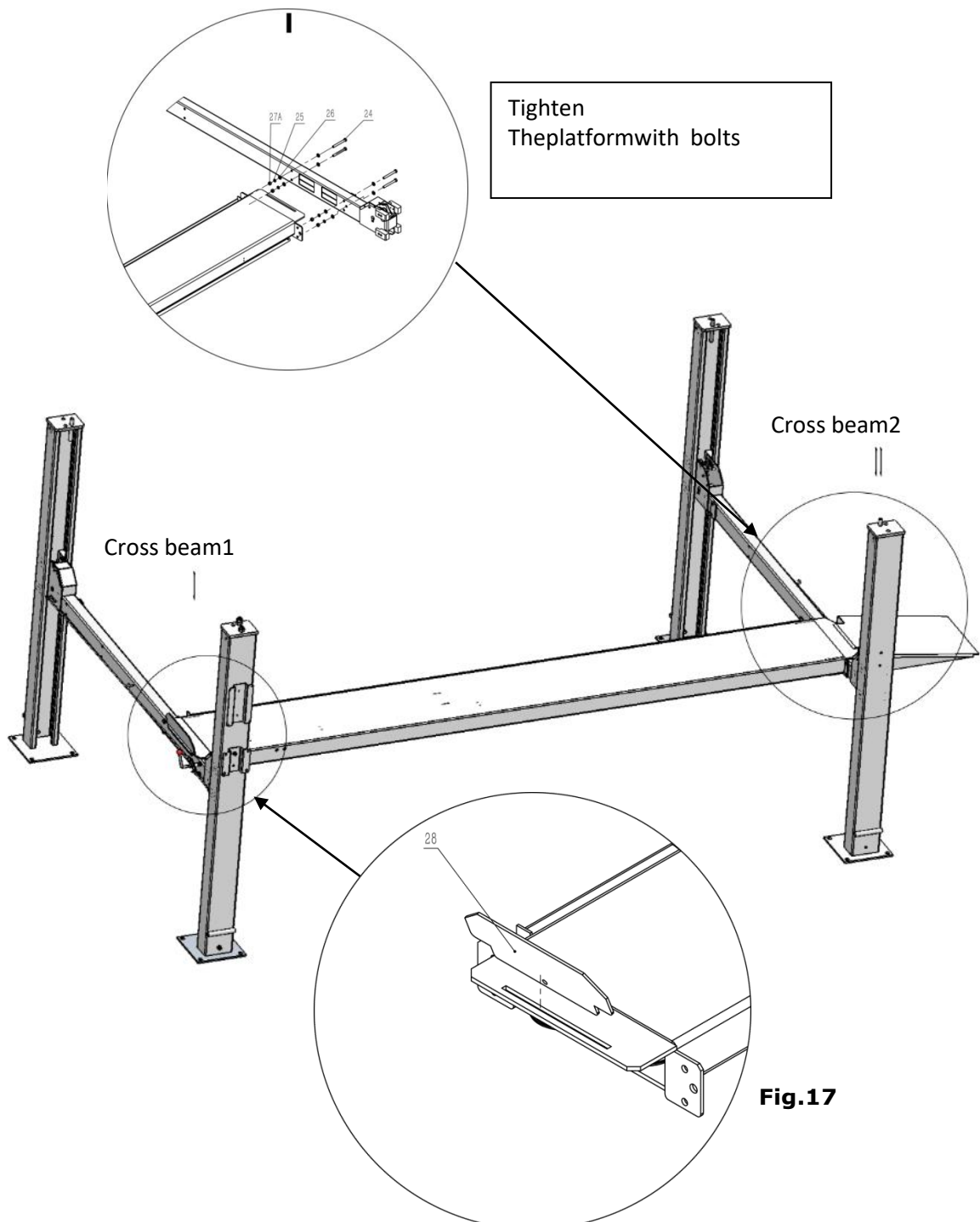
**2. Install the tire stop plate and connecting bolts:** Tighten the platform and the cross beam **1** with bolts. Tighten the tire stop plate , platform and cross beam **2** with bolt.

Note: Install the tire stop plate on the drive- in position . And the bolts for connecting with tire stop plate is longer, pay attention when choosing the bolts. **(See Fig.17)**

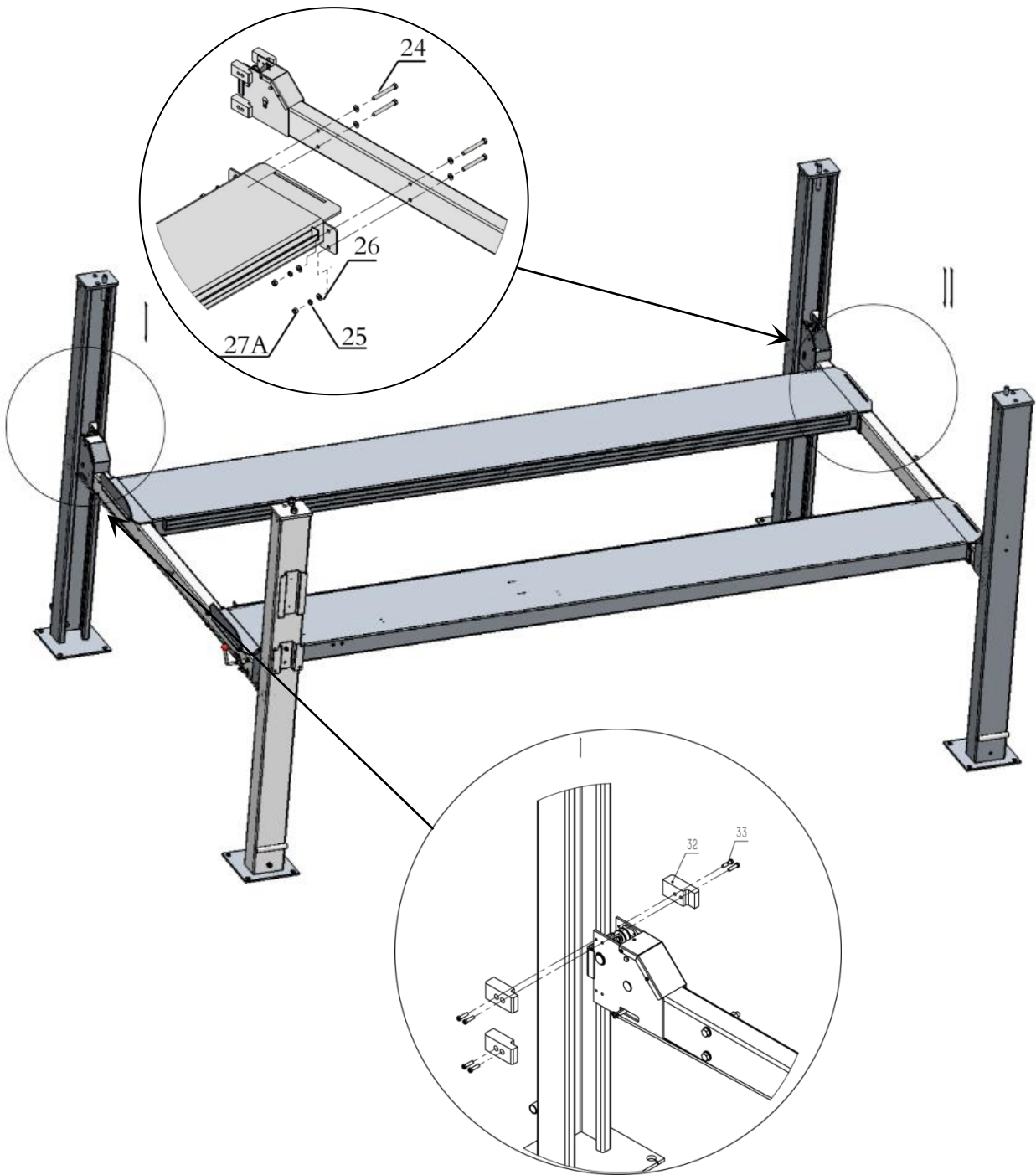
Instruction : 1) This lift is designed to be driven in at any position according to the space.

Below is the instruction for the drive -in position on cross beam 1. If it is chosen to be driven in from cross beam 2, install the tire stop plate to the other side only.

2) Powerside column can be installed at any position accordingly. But the power unit must always be installed adjacent to the safety lock release handle. Pay attention to direction when installed the safety lock release handle, power unit and hydraulic system.



**G. Install the offside platform and limit slide block, and platform strengthen bolts. Check the verticality of columns with level bar and adjust with shims. (See Fig. 18)**

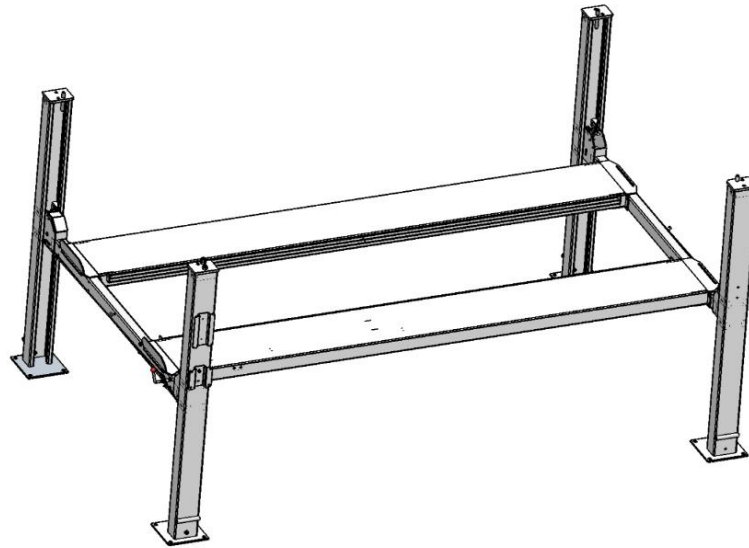


**Fig.18**

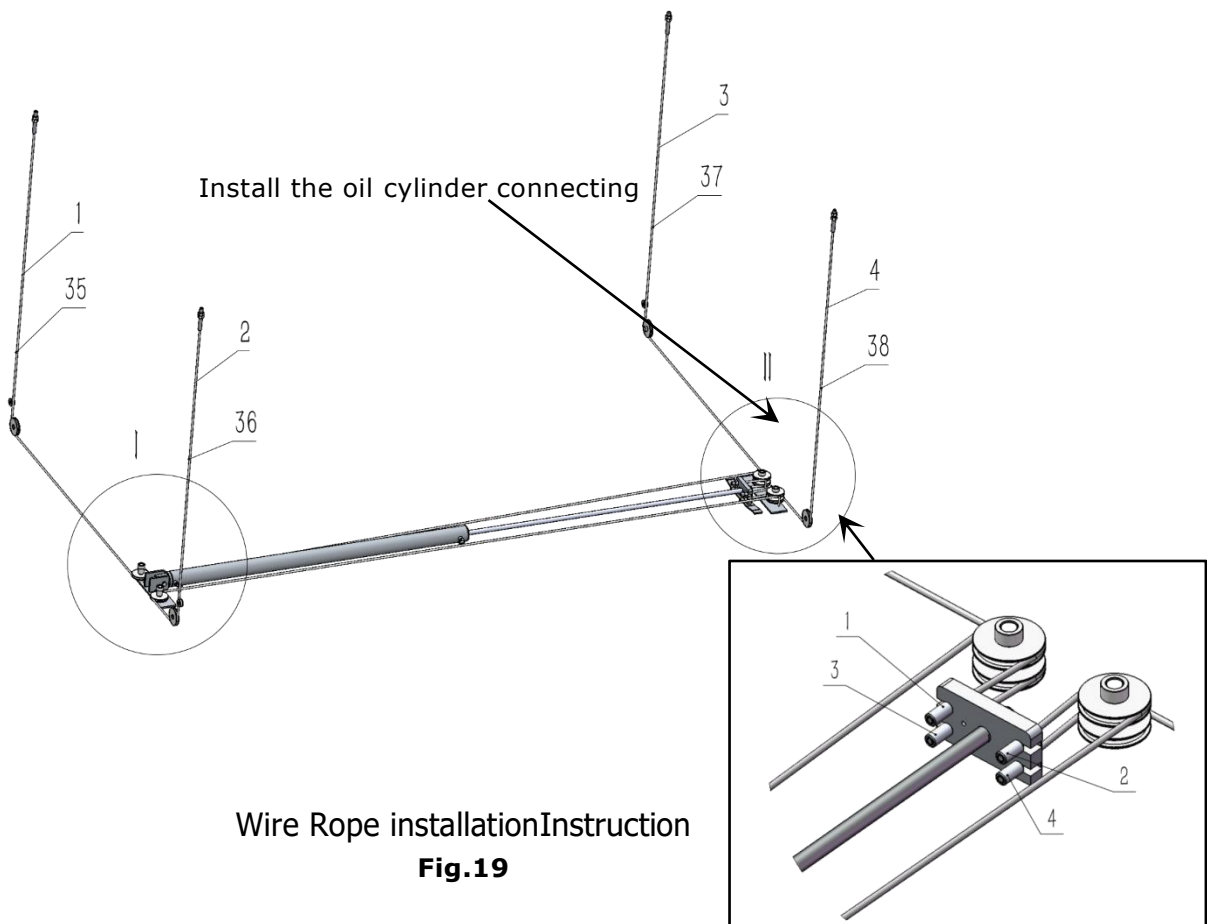
## H. Illustration for Wire Rope installation

1. Route the Wire Rope from the powerside platform via the pulleys according to the number below and then connect them to the columns.

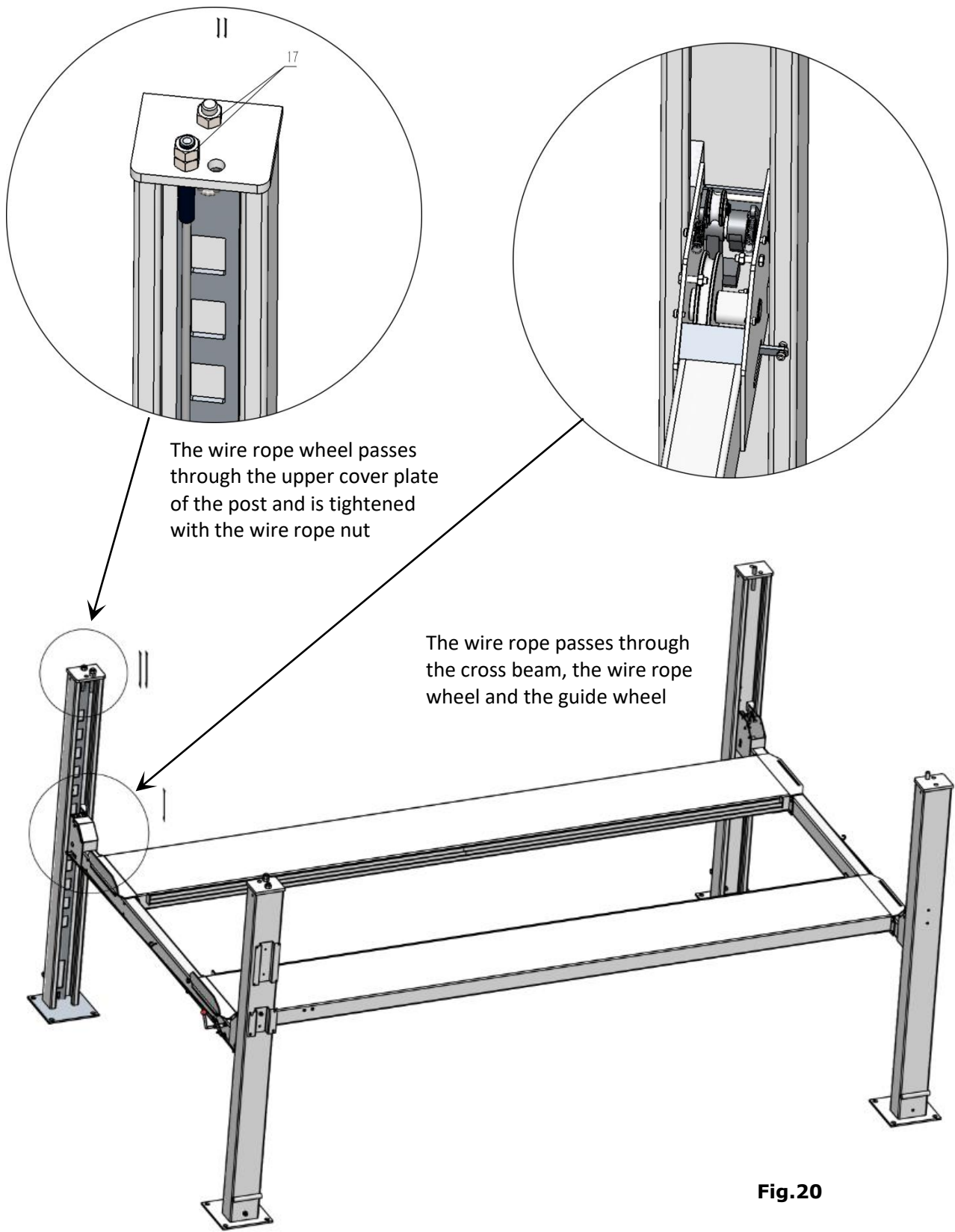
(See Fig. 19)



NO.	①	②	③	④
Wire Rope				
Length (inc. connecting fitting)	8945mm (352.16")	7520mm (296.06")	4465mm (175.78")	3020mm (118.89")

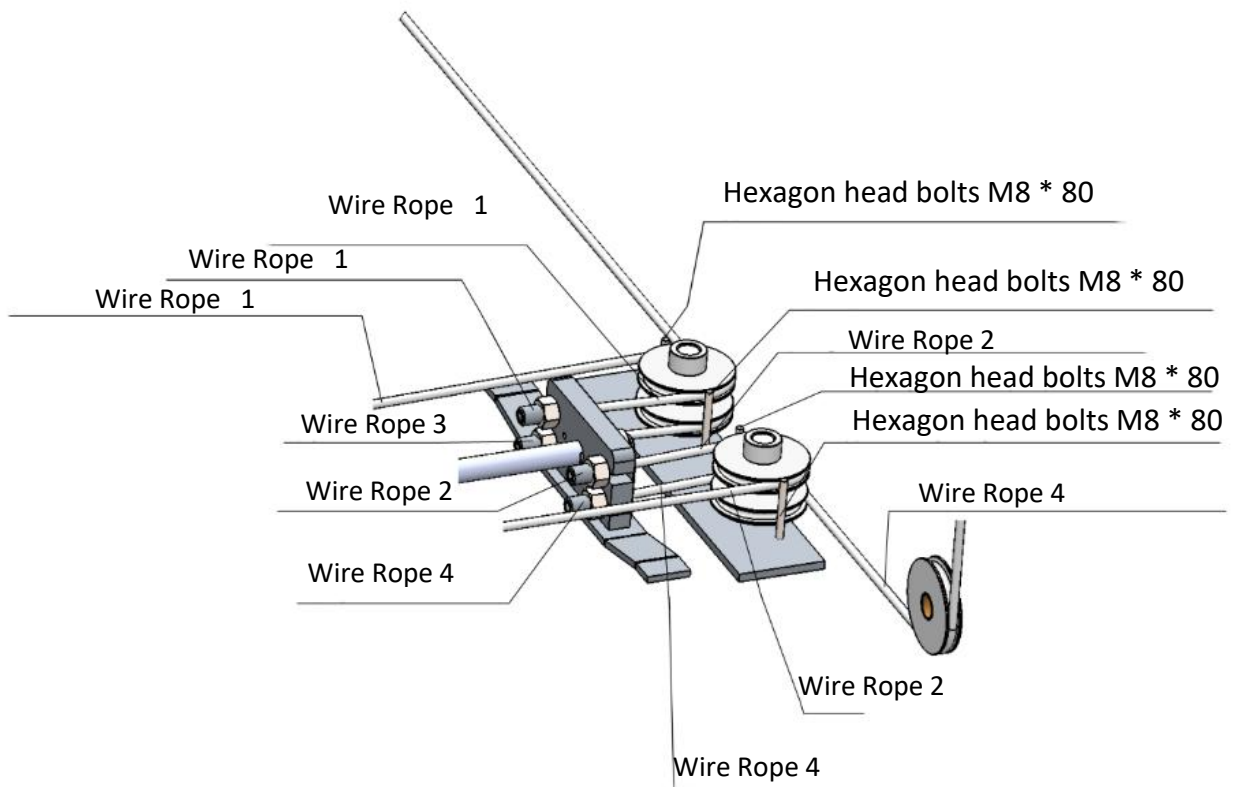
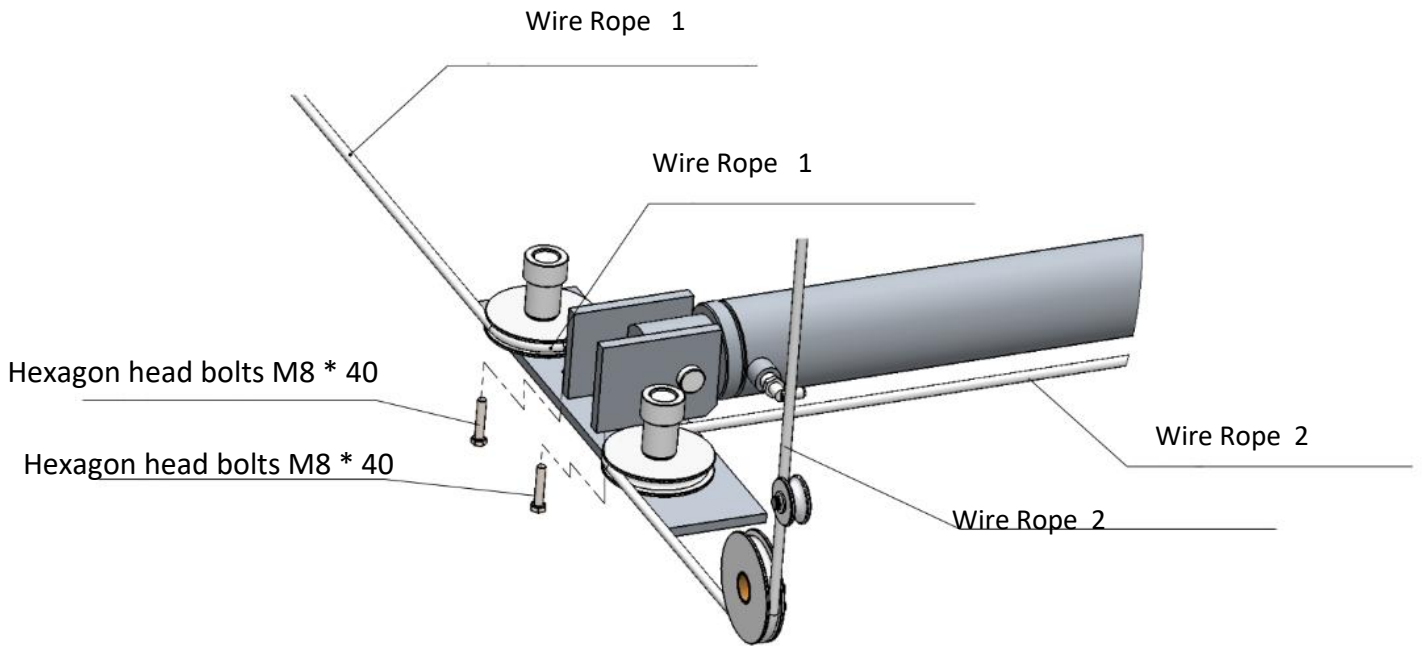


2. The cable goes through the cross beam to column top plates and tightened with cable nuts  
(See Fig. 20)



**Fig.20**

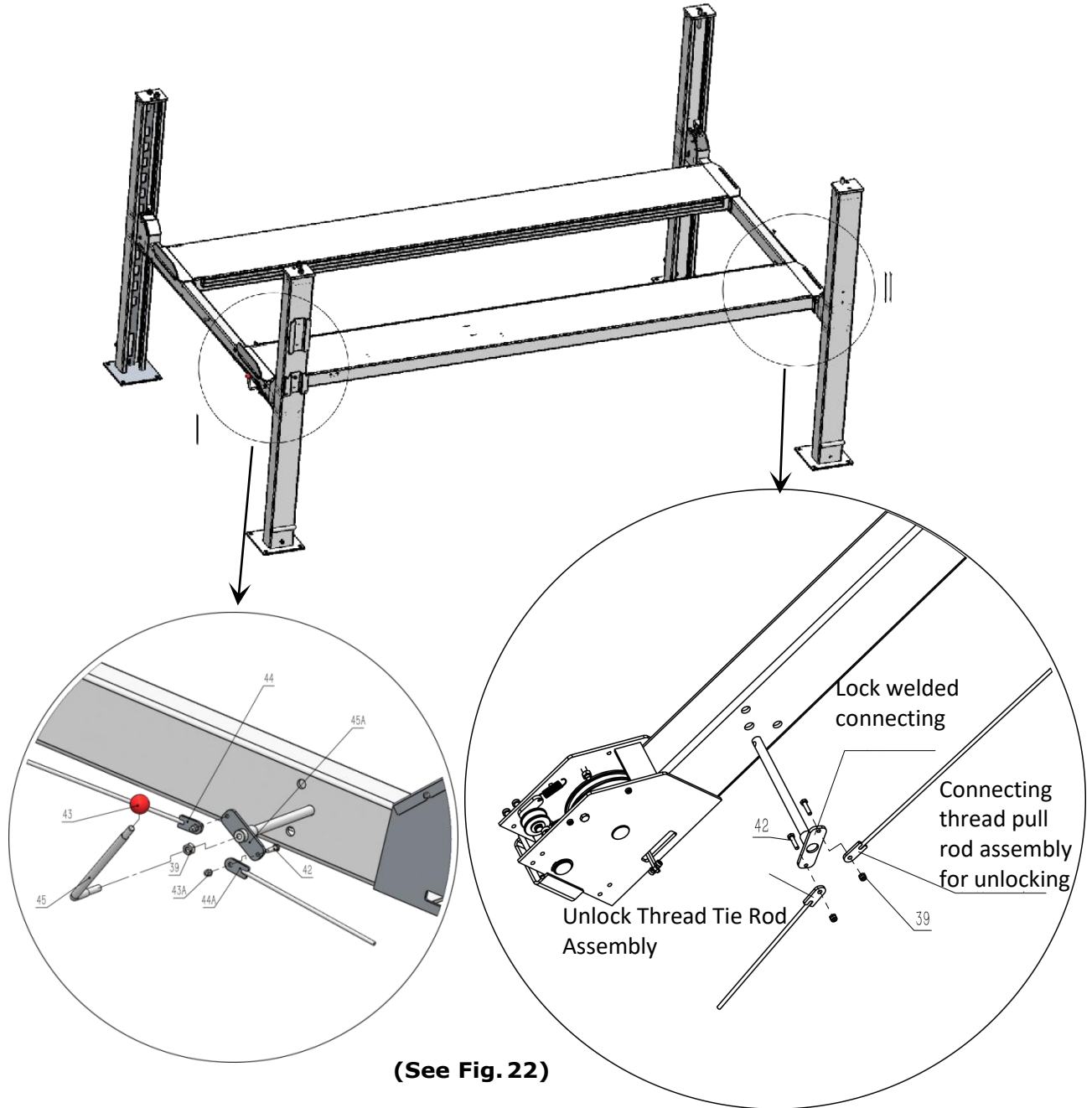
3. Illustration for cables under platform . (See Fig. 21)



(See Fig. 21)

**I. Install release handle assy. (See Fig. 22)**

Noted: Power unit must be installed near the safety release handle.



**Safety Lock Connection System**

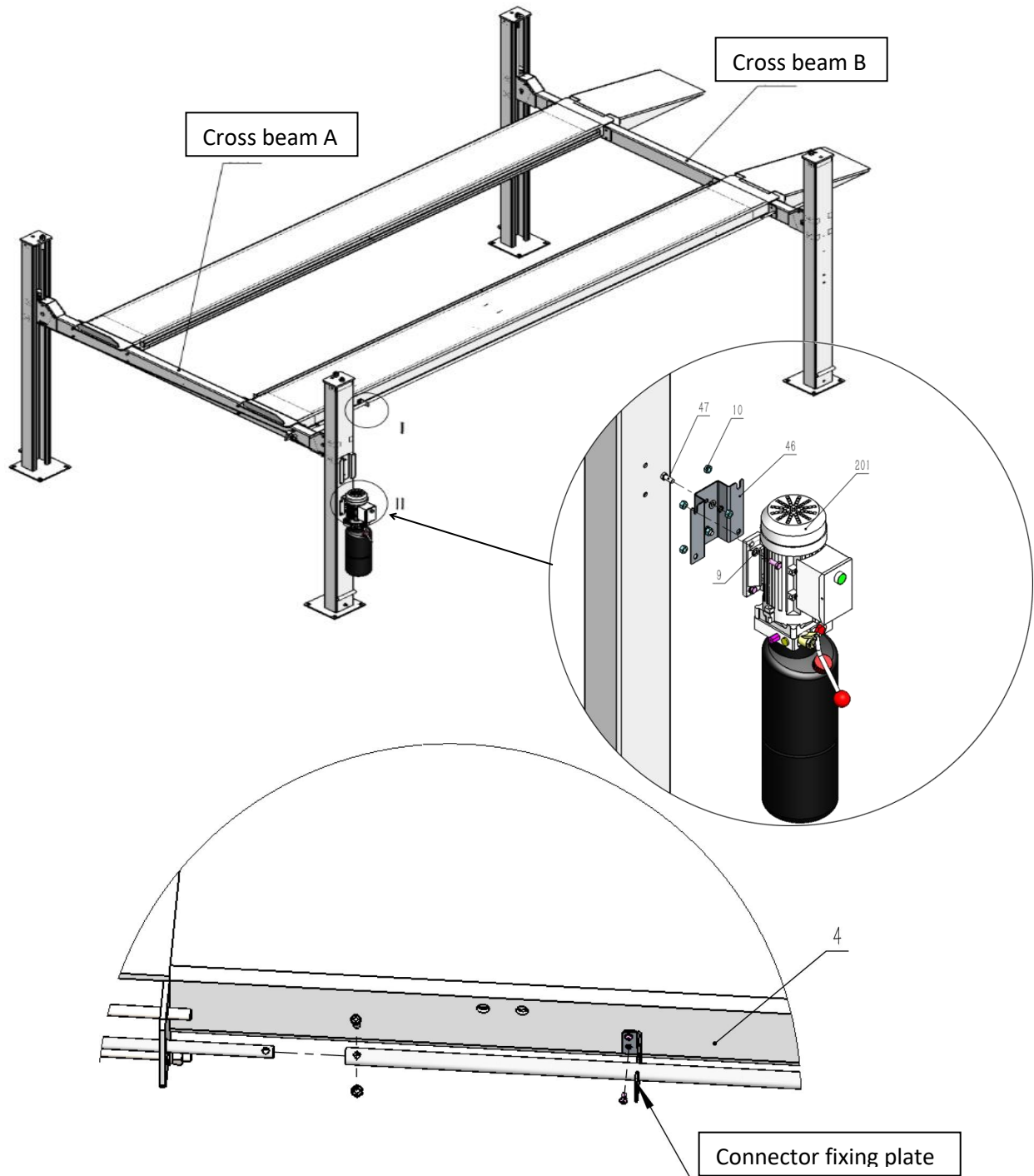
Fix the welding of the unlocking tie rod and the safety lock handle. The welding of the unlocking tie rod is connected with the Hexagon head bolt of M6X25 and the hexagon locking nut of Type 1 non-metal insert and the unlocking thread tie Rod Assembly..

Fix The unlock tie Rod Welding, the unlock tie rod welding is equipped with M6X25 hexagon head bolt and Type 1 non-metal Insert Hexagon lock nut and unlock thread tie rod assembly, unlock linkage thread tie rod assembly to connect.

**J. Install power unit and connecting tube (See Fig. 23).**

Noted: Power unit must be installed near the safety release handle.

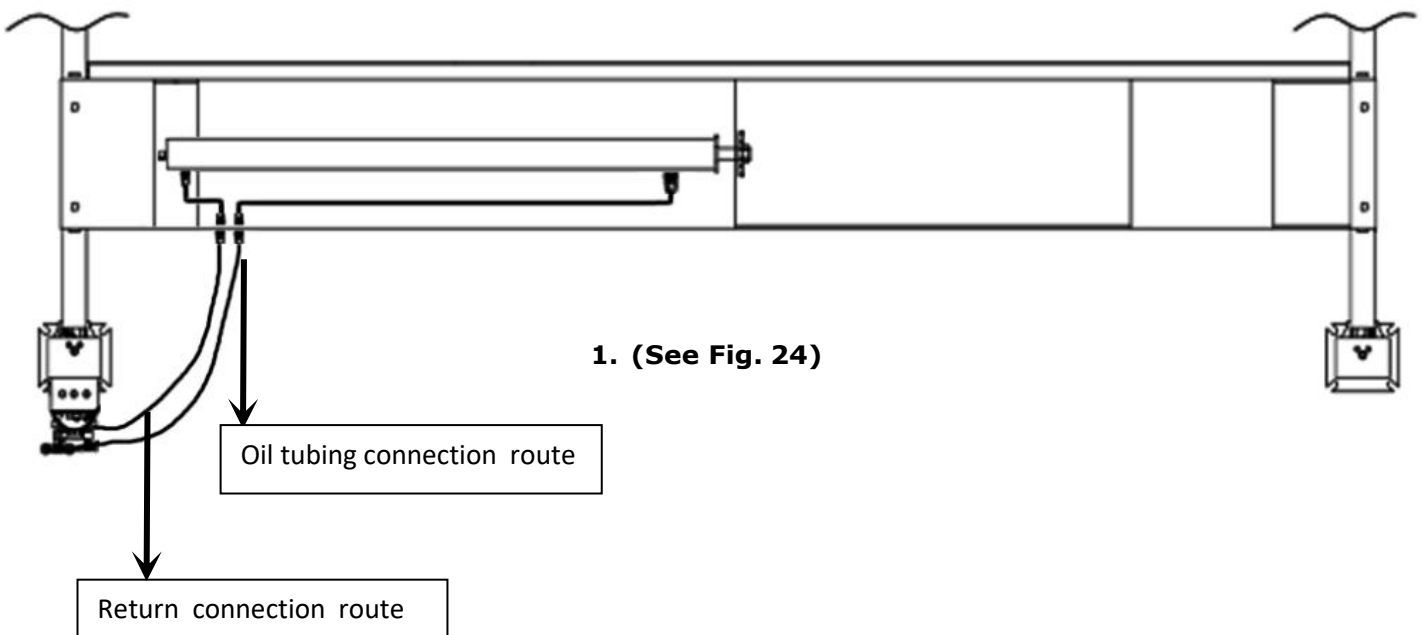
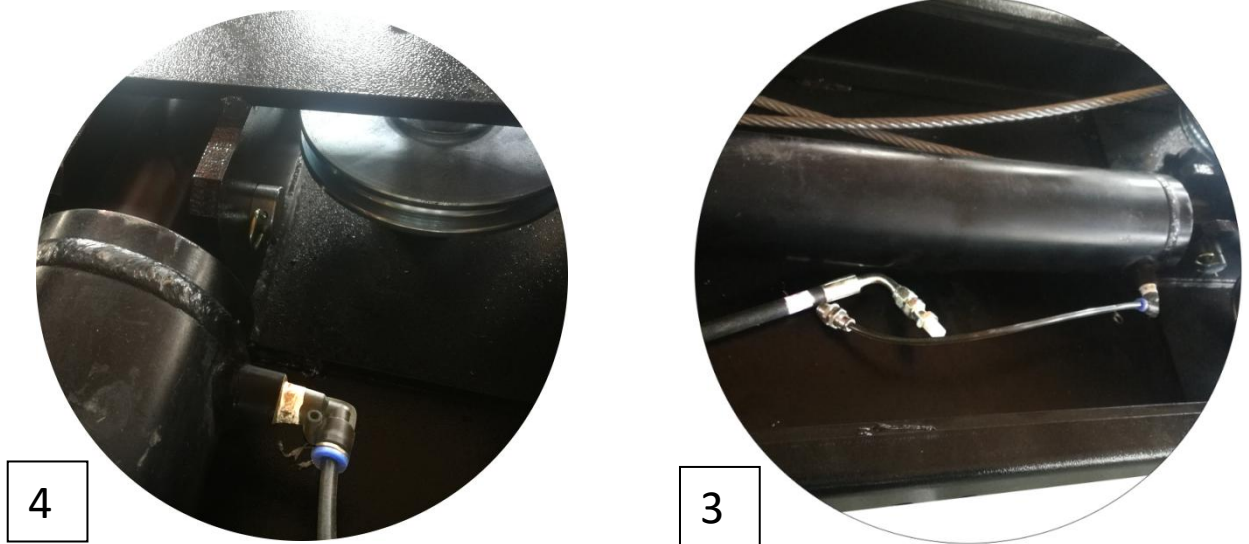
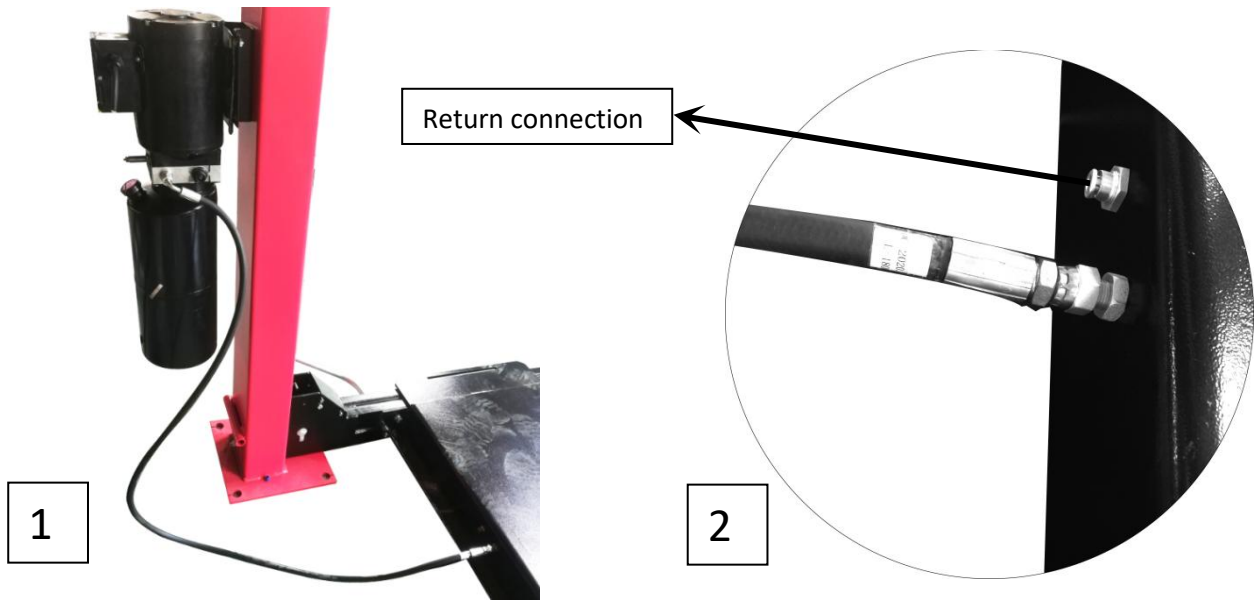
**1. Install Power unit on the cross beam A**



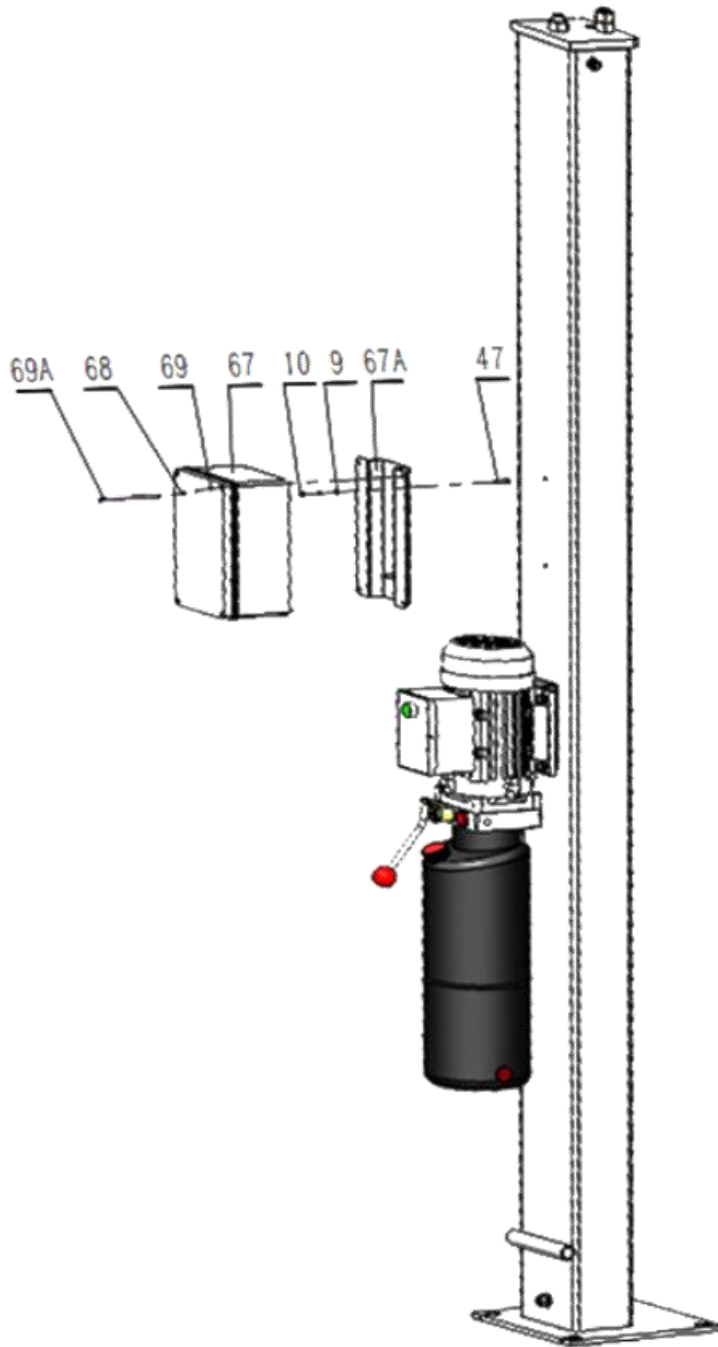
**(See Fig. 23)**

M8x35, hexagon socket head bolts are used to secure the connecting pipe and connecting rod of the safety device

**K. Install Hydraulic System (See Fig. 24)**



- L. Install the control box( See. Fig.25)  
(Electric control box is optional)



**Fig.25**

Note: When the cross beam goes to highest place, the cross beam slide block touched the high limit switch drive bar and the lift stop rising.

M、 Circuit diagram (See Fig.26)

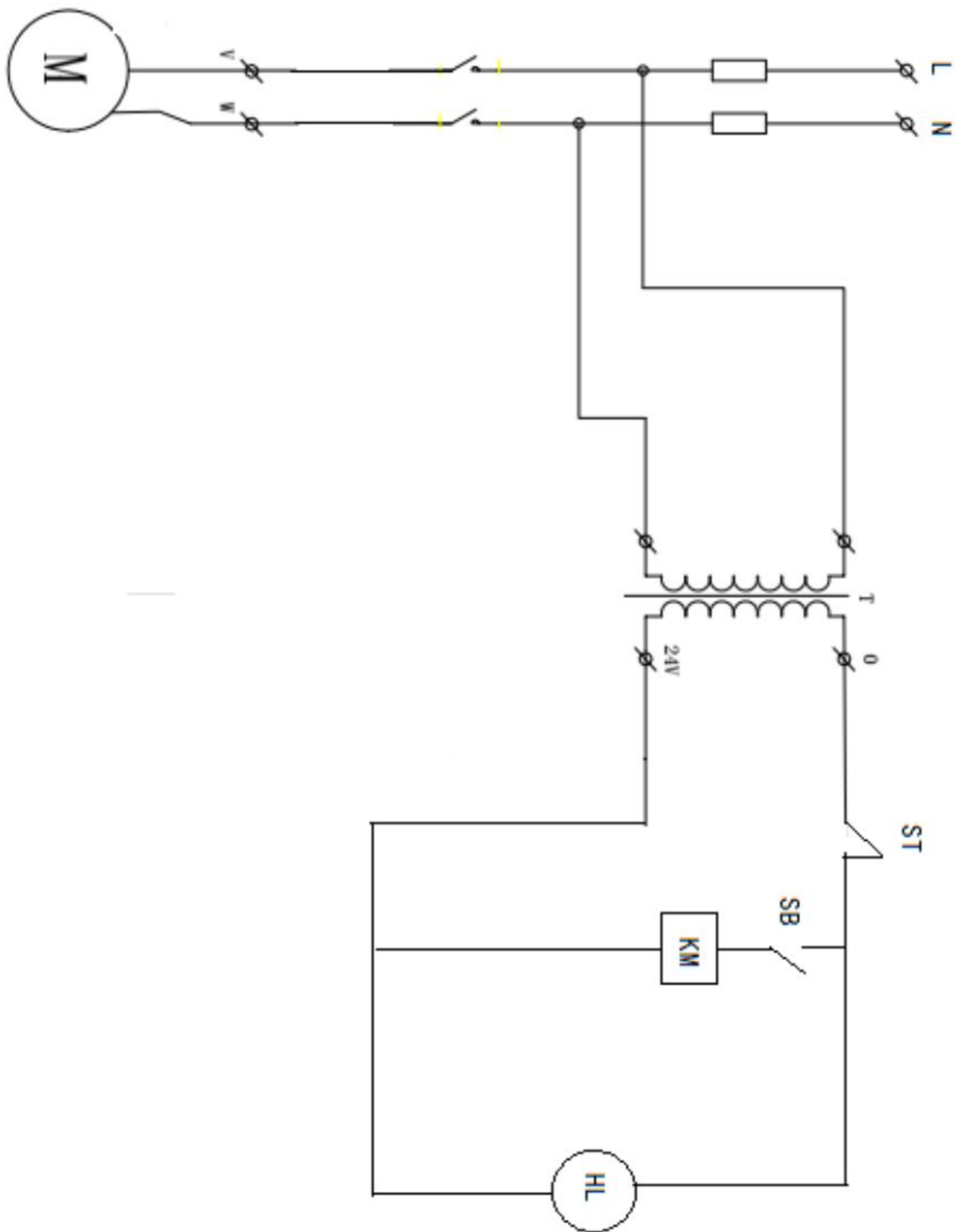
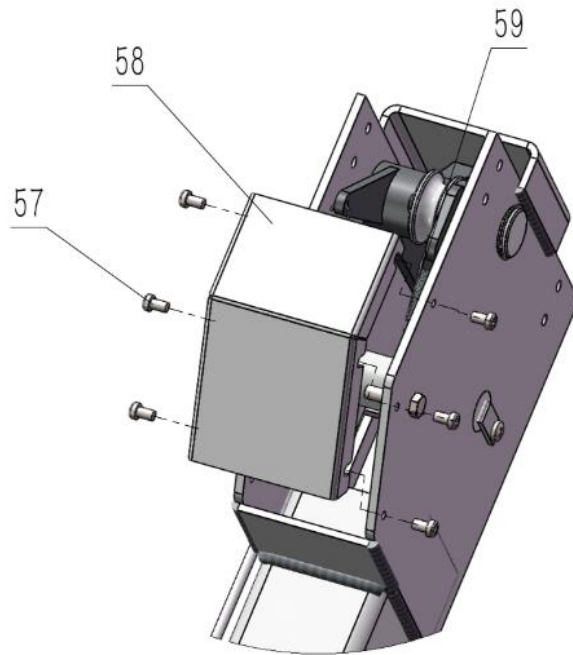


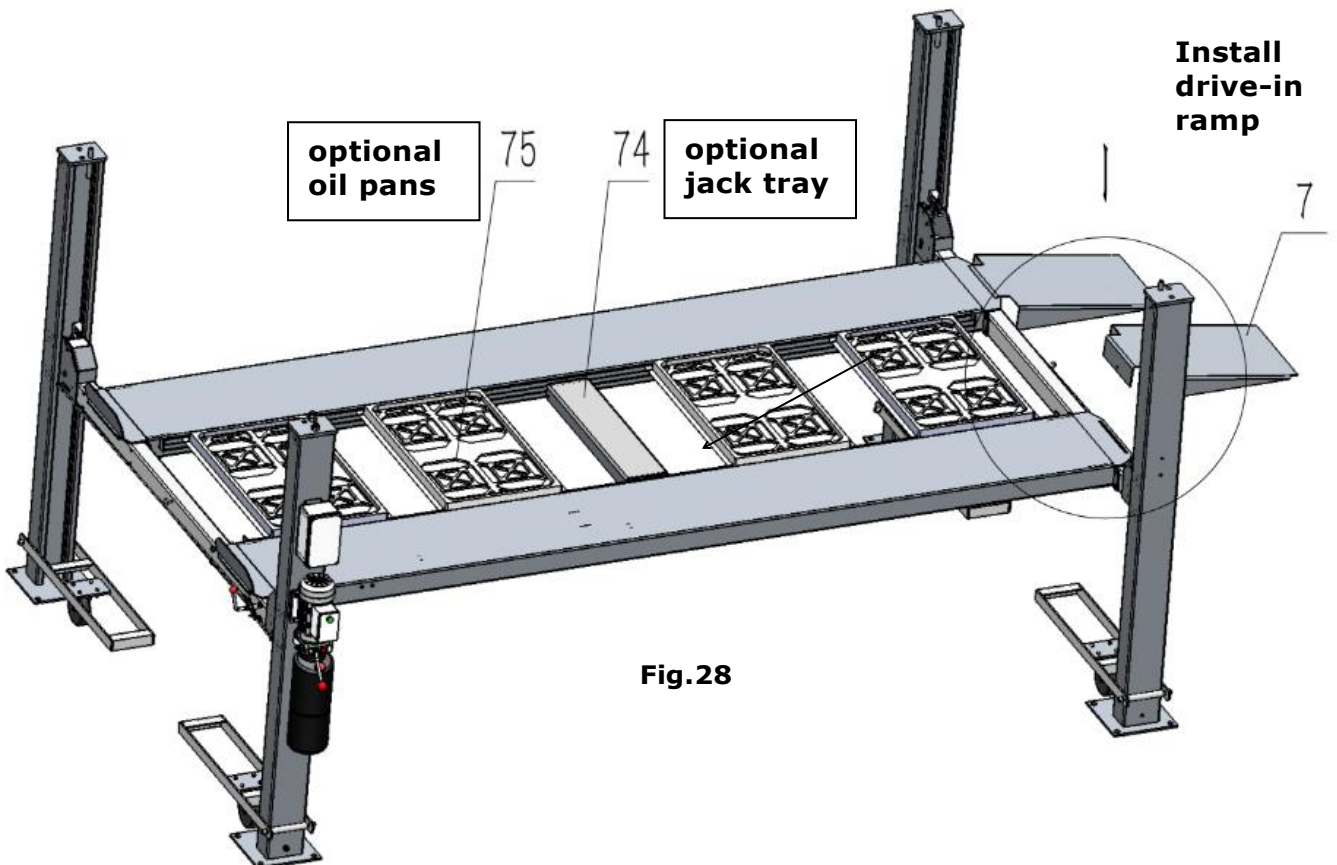
Fig. 26

**N. Install spring and beam safety cover of cross beam (See fig .27 ).**



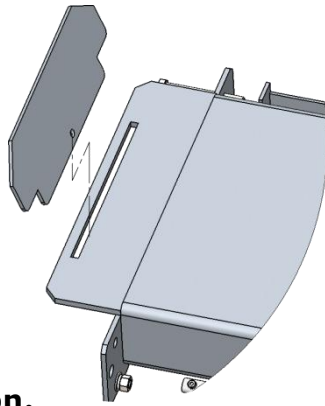
**Fig. 27**

**N. Install drive-in ramp, optional jack tray and optional oil pans (See Fig. 28).**  
then attach the drive-in ramp.



**Fig.28**

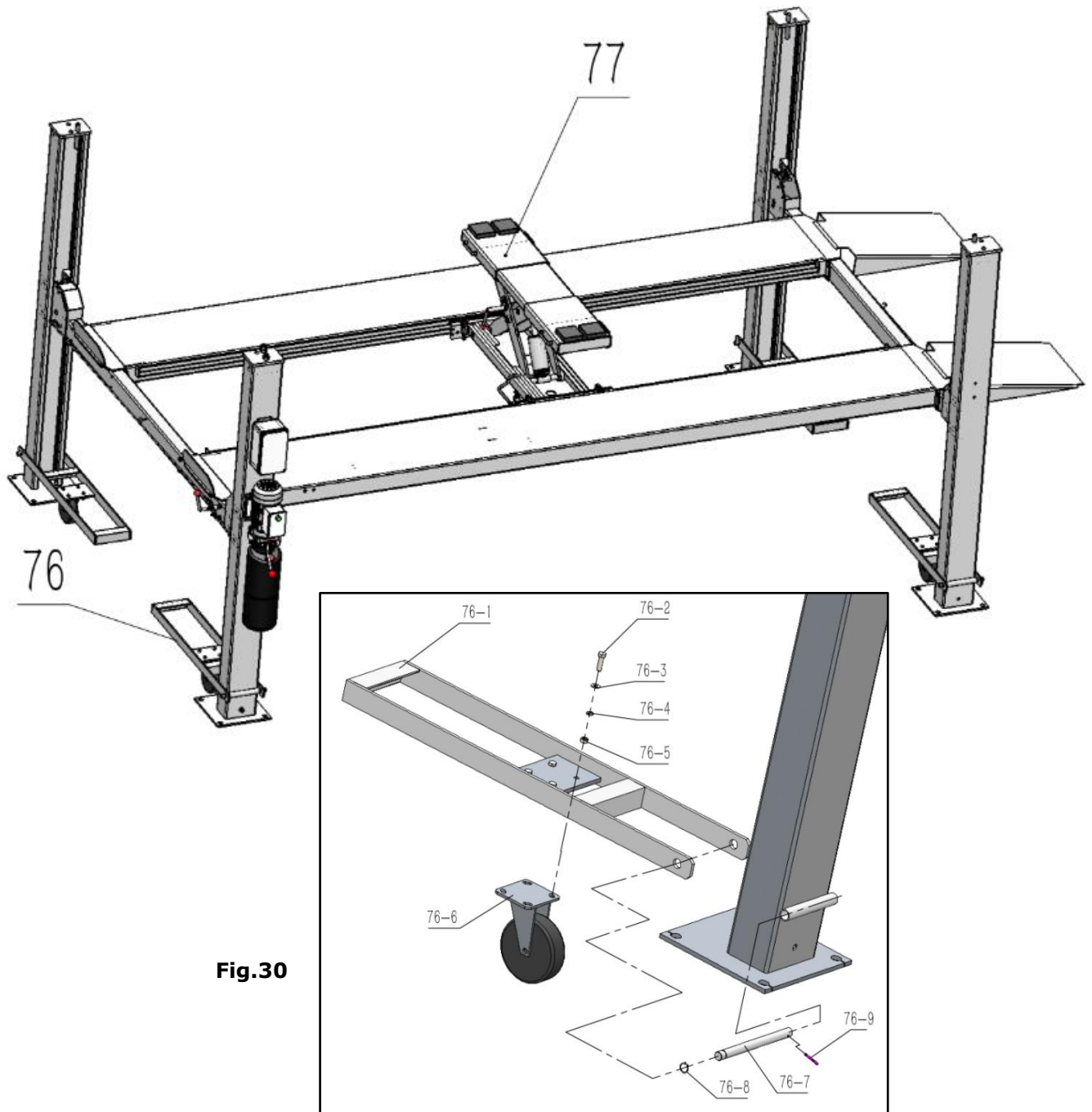
**O. Install front wheel platform baffles (See Fig. 29**



**Fig.29**

**P. For optional kits installation.**

1. Install optional caster kits or jack(assembly body)-----optional (**See Fig. 30**)



**Fig.30**

2. Install motor fixing bracket (See Fig. 31)

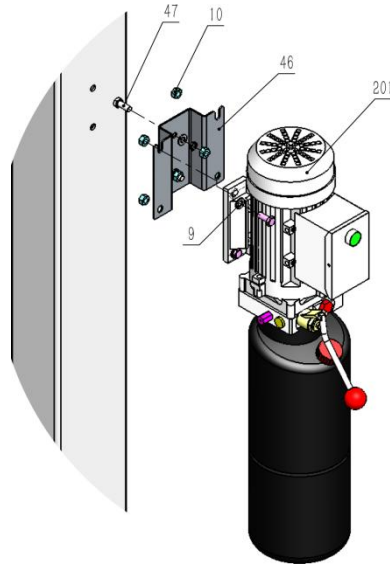


Fig.31

Q. Fix the anchor bolts

1. 1. Prepare the anchor bolts (See Fig. 32)

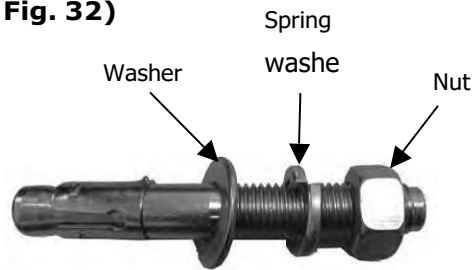


Fig.32

1.2 Adjust the column with the leveling bar and leveling pad , drill the anchor hole and install the anchor bolts. Tap the anchor bolts into the anchor hole with a hammer and tighten the bolts.( See Fig.34)

Note: The tightening torque for the anchor bolt is 150N.m.  
Tap anchor bolts into the anchor hole at least 90mm deep.

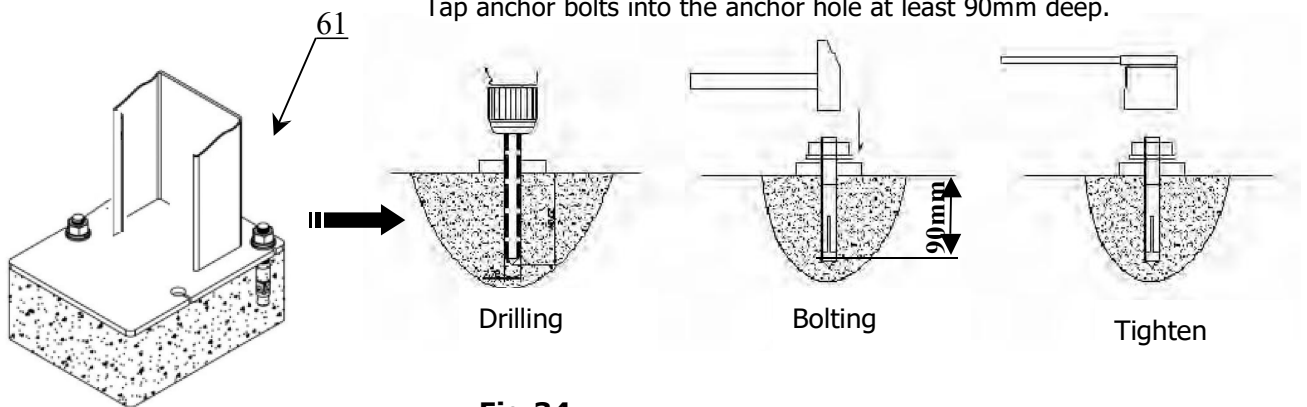
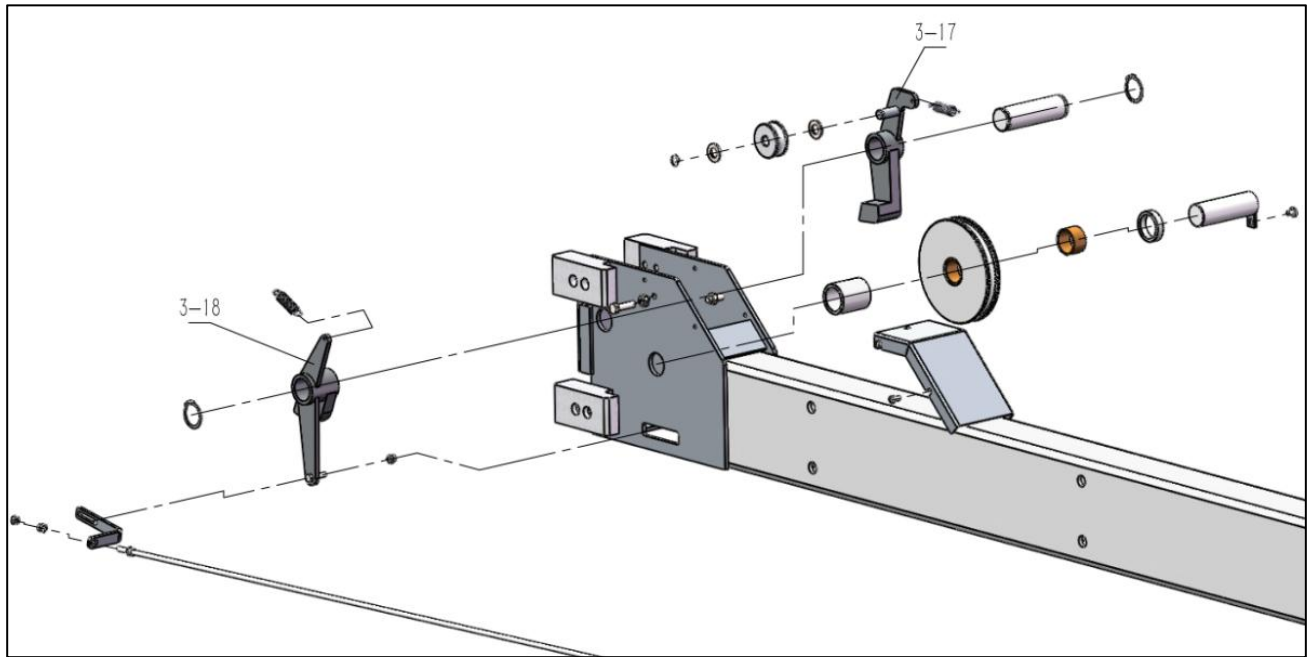
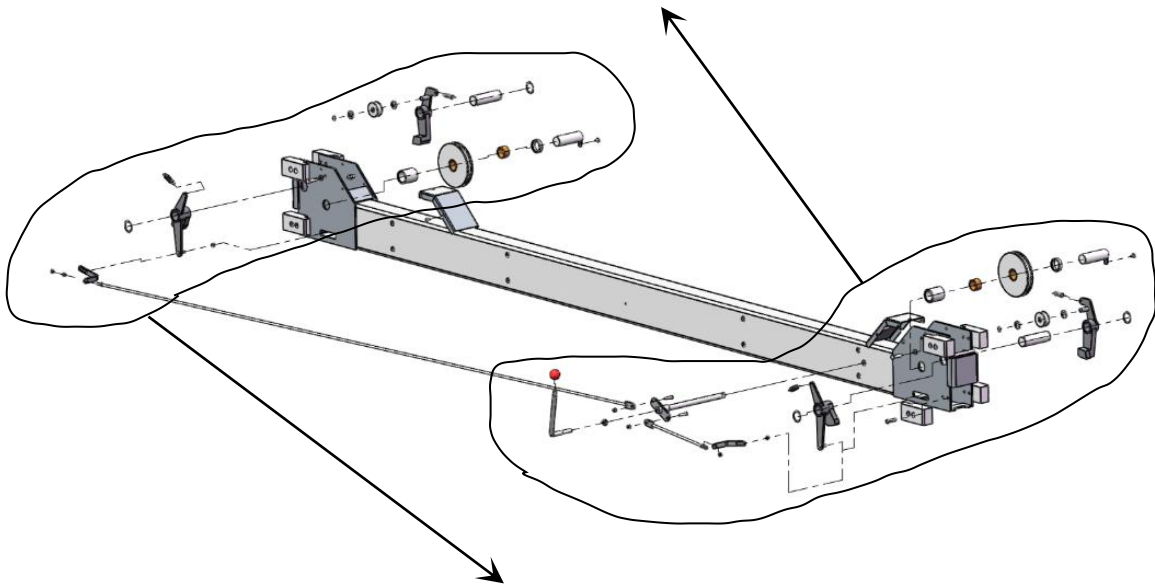
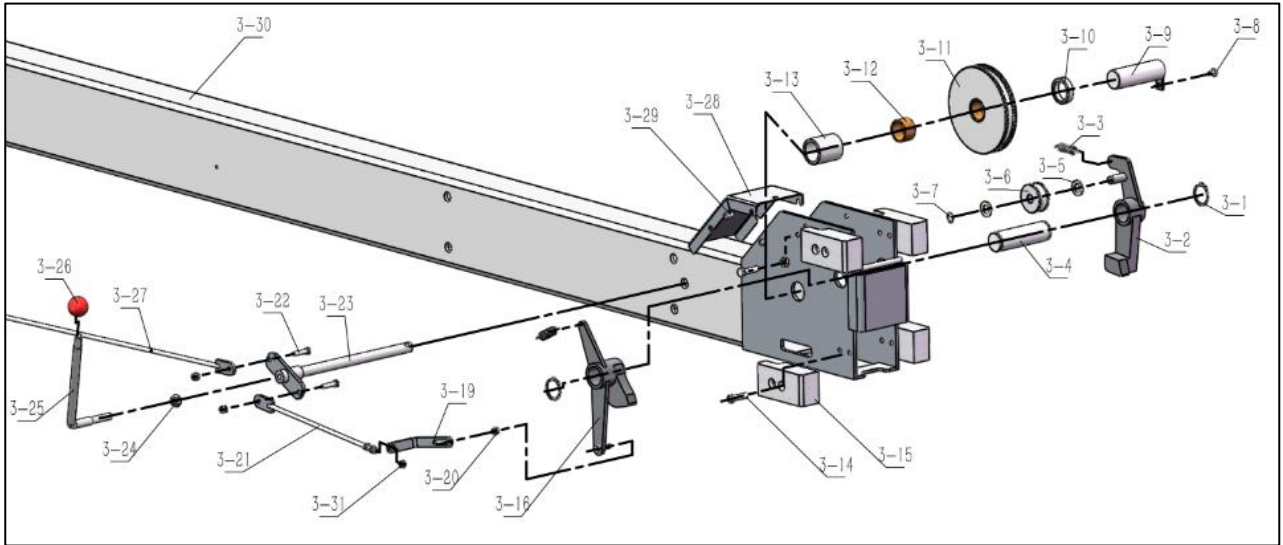


Fig.34

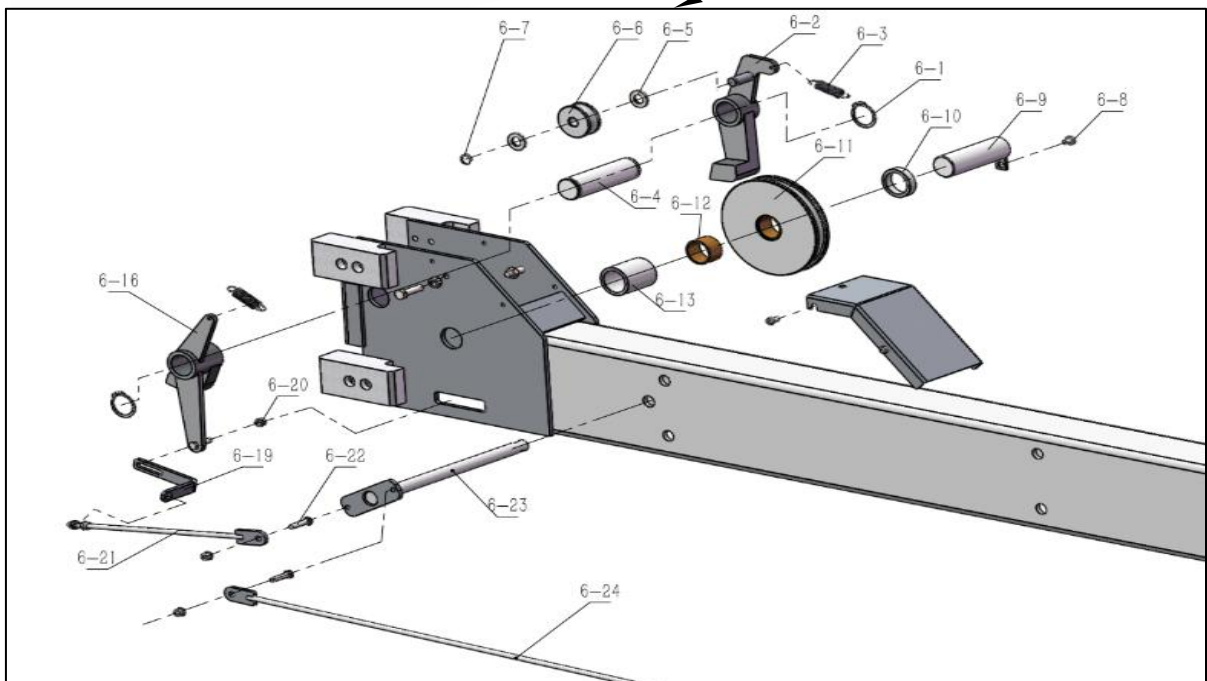
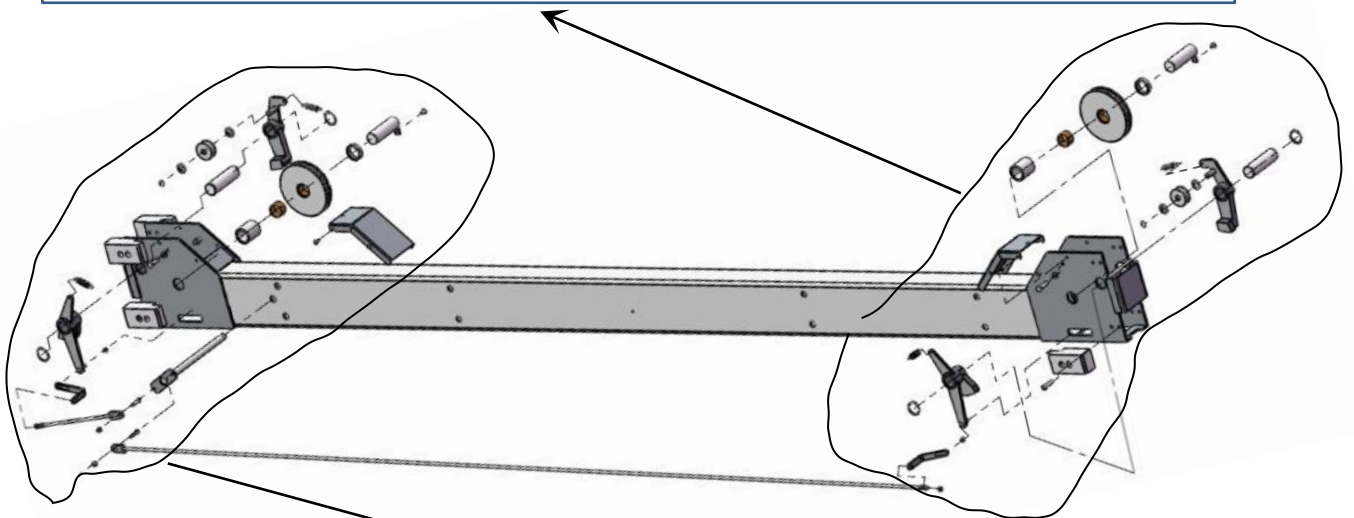
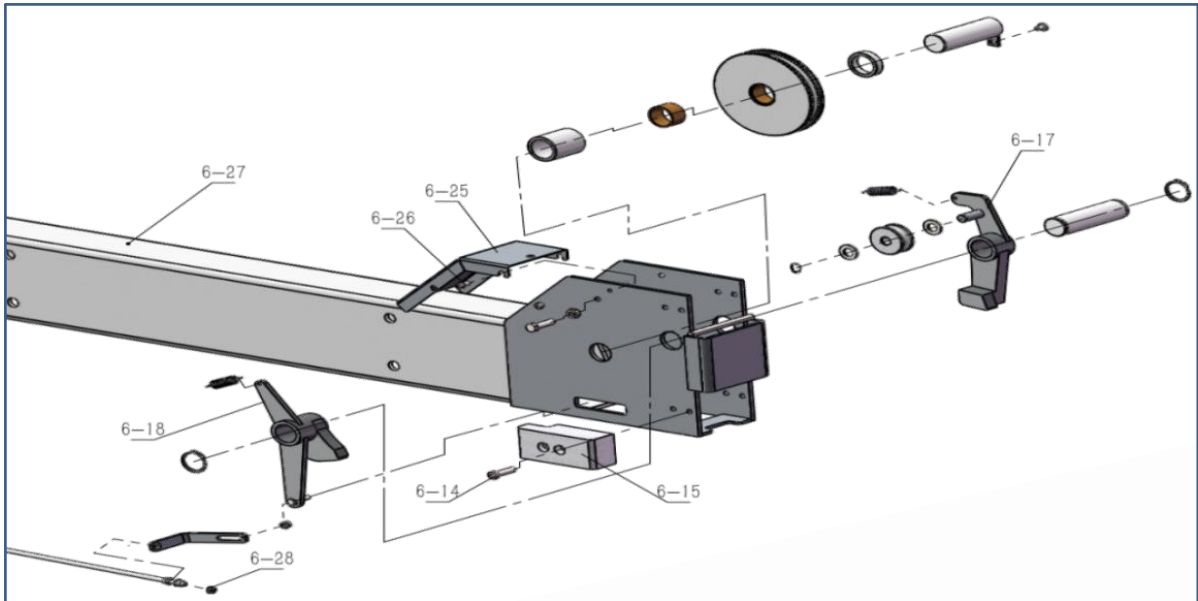


# Main crossbeam

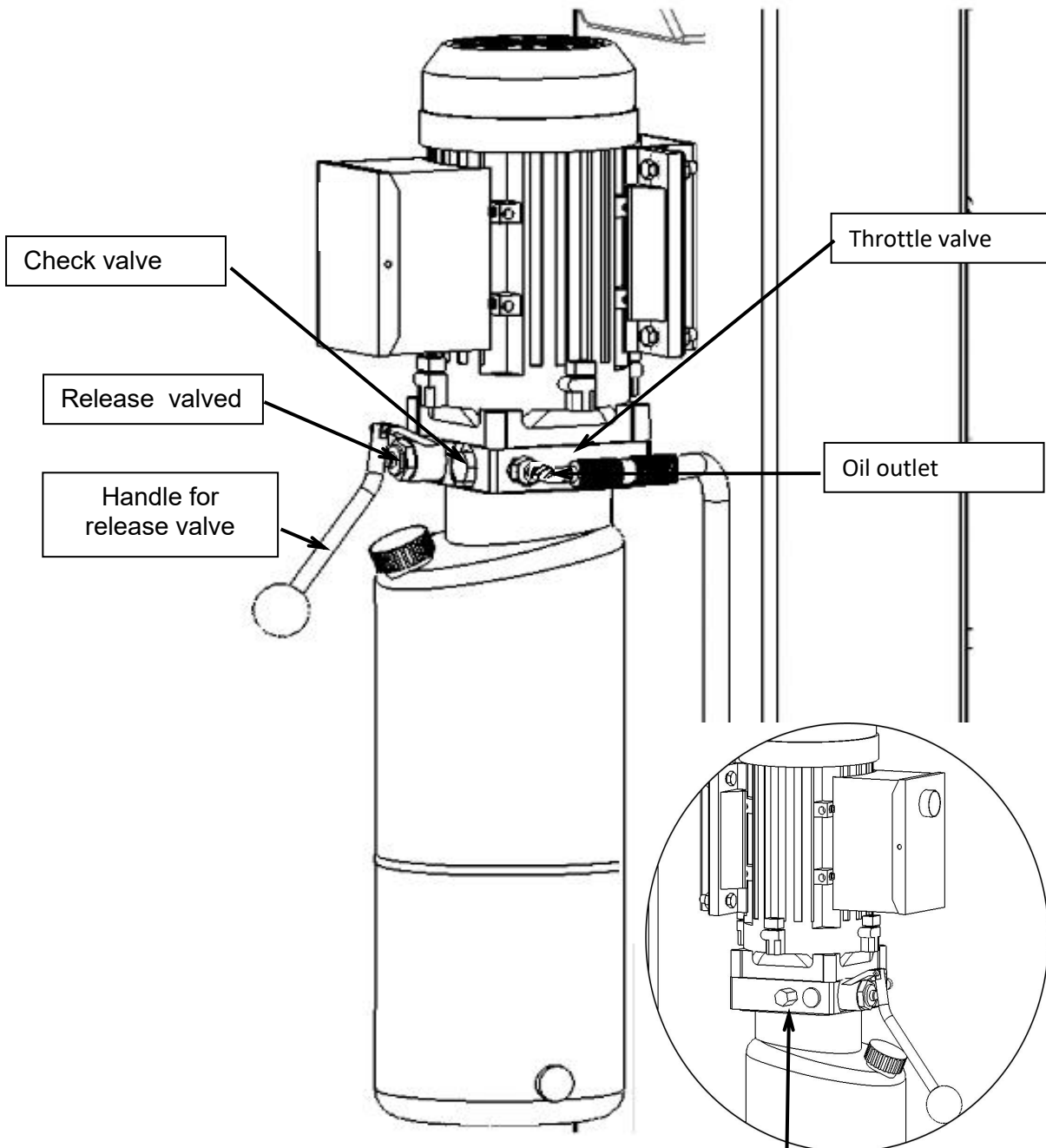


# Detail table of main crossbeam decomposition

## Secondary Crossmember



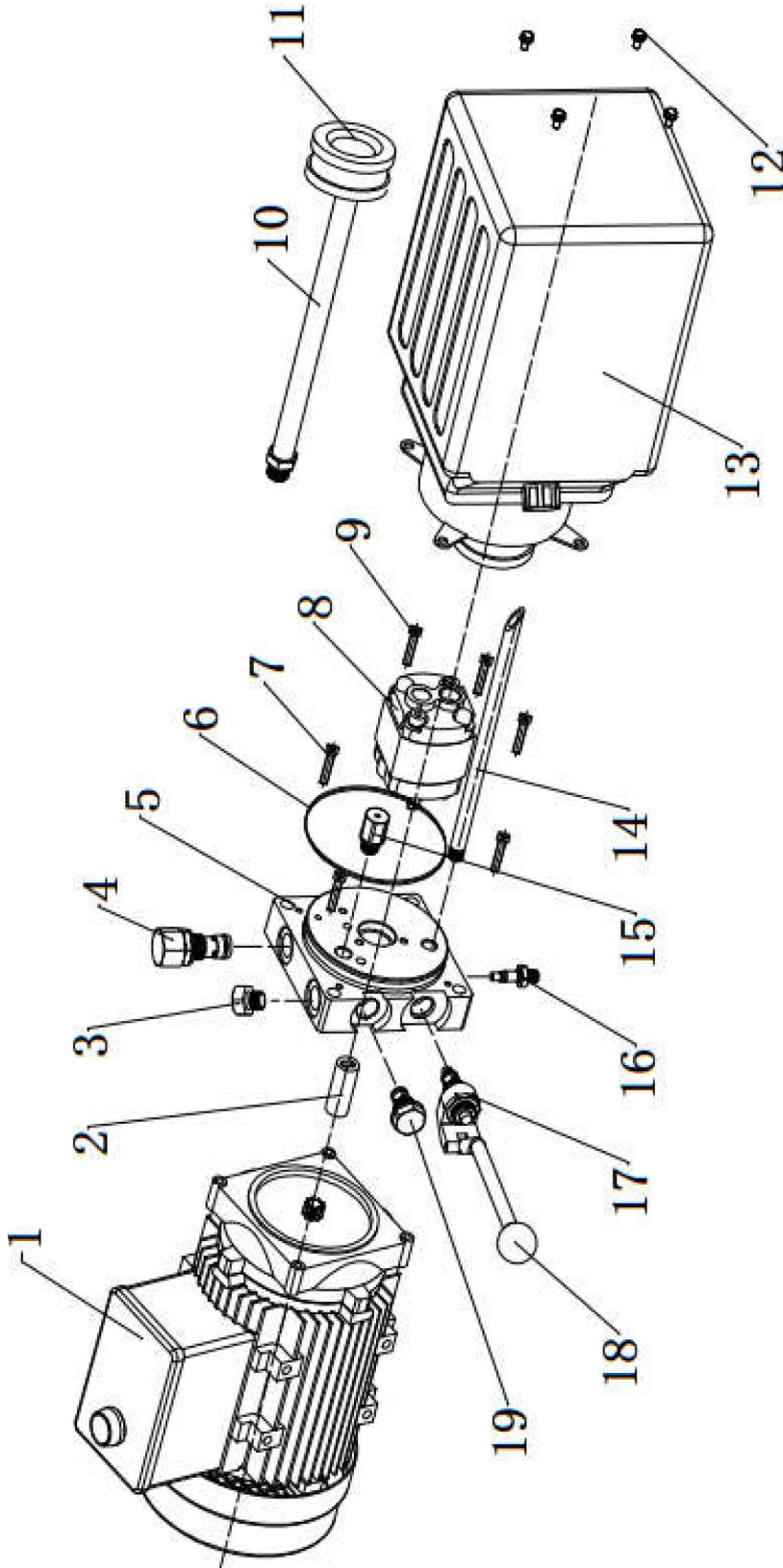
# Motor Function Analysis



Check valve :Prevent reverse flow of oil  
 Overflow valve :Adjusting oil pressure  
 Throttle valve :Adjusting the descent rate

Overflow valve

## Motor drawing and part list



Nos.	Name	Quantity
1	Iron motor	1
2	Motor connecting shaft	1
3	Valve block blockage	1
4	Overflow valve	1
5	Valve Body	1
6	O-Ring	1
7	Valve Body Bolt	4
8	Gear Pump	1
9	Gear Pump Bolt	2
10	Oil Inlet Pipe	1

Nos.	Name	Quantity
11	Filter	1
12	Socket bolt	4
13	oil storage tank	1
14	Oil Return Pipe	1
15	Buffer Valve	1
16	Throttle valve	1
17	Release valved	1
18	Handle for release valve	1
19	Check valve	1
20		

#### **IV. TEST RUN**

1. Fill the reservoir with Hydraulic Oil
2. Press buttonControl box  till the cables are strained. Check the cables and confirm they are in the proper pulley position. Make sure the cables are not across.
3. When the Power Unit pressure relief valve is pressed down, the cross beam will be locked to the safety ladders and then adjust the platforms to be level by adjusting the nuts of safety Ladder. Tighten the nuts above and under the safety ladder top plate after leveling.
4. Adjust the cable fitting hex nuts to make platforms and four safety locks work synchronously. You need to run the lift up and down for several times, meanwhile do the synchronous adjustment till the four safety devices can lock and release at the same time.
5. After finishing the above adjustment, test running the lift with load. Run the lift with platforms in low position first, make sure the platforms can rise and lower synchronously and the safety device can lock and release synchronously. And then test run the lift to the top completely.
6. If there are anything improper, repeat the above adjustment.